

**Board Report**

---

**File #:** 2017-0479, **File Type:** Policy**Agenda Number:** 49

---

**REGULAR BOARD MEETING  
JULY 27, 2017****SUBJECT: CRENSHAW/LAX TRANSIT CORRIDOR PROJECT****ACTION: ADOPT RESOLUTION OF NECESSITY TO ACQUIRE PROPERTY INTEREST IN PORTIONS OF PROPERTY LOCATED AT 6700 CRENSHAW BLVD, LOS ANGELES.****RECOMMENDATION**

CONSIDER:

- A. HOLDING a public hearing on the proposed Resolution of Necessity; and
- B. ADOPTING a Resolution of Necessity authorizing the commencement of an eminent domain action to acquire various interests in the property located at 6700 Crenshaw Blvd., Los Angeles. Metro must proceed with a condemnation action to clear various title issues and acquire the necessary property interests required for the Crenshaw/LAX Transit Corridor Project. The properties sought to be condemned are a 162 square foot permanent roadway easement (Metro Parcel CR-2901) and a 50 square foot temporary construction easement (Metro Parcel CR-2901-1) in a portion of 6700 Crenshaw Blvd., Los Angeles, California (APN 4006-025-032) (hereinafter "Property"). The Property is owned by Noel Dias and Mike Davidyan.

(REQUIRES TWO-THIRDS VOTE OF THE FULL BOARD)

**BACKGROUND**

Los Angeles County Metropolitan Transportation Authority ("Metro") seeks to acquire the Property (Attachment "A") for the construction and operation of the Crenshaw/LAX Transit Corridor Project ("Project") and in particular to make necessary street modifications to Crenshaw Blvd. and 67th Street. Metro's review of title records has revealed that title to the property is held by Mike H. Davidyan and Noel Dias. An initial offer was presented to Mr. Dias on July 1, 2016 and, as a result of some unresolved title issues, a subsequent written offer was presented to Mr. Davidyan and Mr. Dias ("Owner") on June 29, 2017, as required by California Government Code Section 7267.2. However, there are multiple other parties claiming an interest in the Property and/or have a lien encumbering said Property; accordingly, Metro has not been able to reach a negotiated agreement. The Property is necessary for construction of the Project and for street modification purposes; therefore, staff recommends the acquisition of the Property through eminent domain in order to maintain the Project schedule and to obtain clear title.

In accordance with the provisions of the California Eminent Domain law and Sections 30503, 30600, 130051.13, 130220.5 and 132610 of the California Public Utilities Code (which authorize the public acquisition of private property by eminent domain), Metro has prepared and mailed notice of this hearing to each Owner informing the Owner of its right to appear at this hearing and be heard on the following issues: (1) whether the public interest and necessity require the Project; (2) whether the Project is planned or located in the manner that will be most compatible with the greatest public good and the least private injury; (3) whether the Property is necessary for the Project; and (4) whether either the offer required by Section 7267.2 of the Government Code has been made to the Owner or Owners of Record, or the offer has not been made because the Owner cannot be located with reasonable diligence.

Attached is evidence from staff and legal counsel setting forth the required findings for acquiring the Property through the use of eminent domain (Attachment "B"). After Metro receives all of the testimony and other evidence from all interested parties, the Metro Board must make a determination as to whether to adopt the proposed Resolution of Necessity (Attachment "C") to acquire the Property by eminent domain. In order to adopt the resolution, the Metro Board must find and determine, based upon all the evidence before it and by a two-thirds vote of all the members of its governing body, that the conditions stated above exist.

### **DETERMINATION OF SAFETY IMPACT**

This Board action will not have an impact on Metro's safety standards.

### **FINANCIAL IMPACT**

The funding for the acquisition of the Property is included in the approved Life of Project Budget (LOP) under Measure R, Project 865512 (Crenshaw/LAX Transit Corridor Project), in Cost Center Number 8510, and Account Number 53013 (Acquisition of Land). Since this is a multi-year project, the cost center manager, project manager and Executive Director, Program Management would be responsible for budgeting costs in future fiscal years.

#### **Impact to Budget**

This project is funded with a combination of Local Agency funds, Proposition C 25%, Proposition A 35%, Measure R 35%, Measure R TIFIA Loan, CMAQ and other federal funding sources. No other funds have been considered and there is no additional impact to operations.

### **NEXT STEPS**

If this action is approved by the Board, Metro's condemnation counsel will be instructed to take all steps necessary to commence legal proceedings in a court of competent jurisdiction to acquire the Property interest by eminent domain. Counsel will also be directed to seek and obtain an Order of Prejudgment Possession in accordance with the provisions of the eminent domain law as necessary.

**ATTACHMENTS**

Attachment A - Property Information

Attachment B - Staff Report

Attachment C - Resolution of Necessity

Prepared by: Carol A. Chiodo, Director of Real Property Management & Development, (213) 922-2404

Calvin E. Hollis, Senior Executive Officer, Countywide Planning & Development, (213) 922-7319

Reviewed by: Therese W. McMillan, Chief Planning Officer, (213) 922-7077

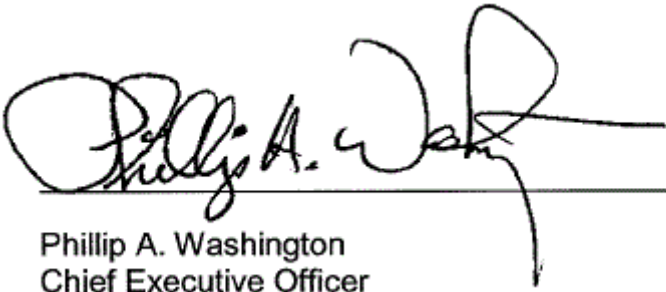

Phillip A. Washington  
Chief Executive Officer

**ATTACHMENT A**

<b>Assessor's Parcel Number</b>	<b>Parcel Address</b>	<b>Property Owner</b>	<b>Purpose of Acquisition</b>	<b>Property Interest(s) Sought</b>	<b>METRO Parcel Number</b>
4006-025-032	6700 Crenshaw Blvd., Los Angeles, CA	Noel Dias, Michael Davidyan	Street realignment/modifications.	Permanent Easement and Temporary Construction Easement	CR-2901 & CR-2901-1



## ATTACHMENT B

### STAFF REPORT REGARDING THE NECESSITY FOR THE ACQUISITION OF A PERMANENT EASEMENT AND A TEMPORARY CONSTRUCTION EASEMENT IN A PORTION OF 6700 CRENSHAW BLVD., LOS ANGELES (THE "PROPERTY") FOR THE CRENSHAW/LAX TRANSIT CORRIDOR PROJECT

#### **BACKGROUND**

A 162 square foot permanent easement and a 50 square foot temporary construction easement in the Property are required for the construction and operation of the Crenshaw/LAX Transit Corridor Project ("Project"). The Property sought is a portion of 6700 Crenshaw Blvd., Los Angeles, CA (APN 4006-025-032). No complete parcels are sought to be acquired and no residences or businesses will be displaced by acquisition of the Property. The address, record owner, physical description, and nature of the property interests sought to be acquired for the Project are summarized as follows:

<b>Assessor's Parcel Number</b>	<b>Parcel Address</b>	<b>Property Owner</b>	<b>Purpose of Acquisition</b>	<b>Property Interest(s) Sought</b>	<b>METRO Parcel Number</b>
4006-025-032	6700 Crenshaw Blvd., Los Angeles, CA	Noel Dias, Michael Davidyan	Street realignment/modifications	Permanent Easement and Temporary Construction Easement	CR-2901 & CR-2901-1

A written offer for the Property was presented to the Owner; however, there are multiple other parties claiming an interest in the Property and/or have a lien encumbering said Property and as such, the Los Angeles County Metropolitan Transportation Authority ("METRO") has not been able to reach a negotiated agreement.

#### **A. The public interest and necessity require the Project.**

The public interest and necessity require the Project for the following specific reasons:

1. The population and employment densities in the Crenshaw/LAX Transit Corridor are extremely high and very transit-dependent. The population and employment densities are four times higher than Los Angeles County as a whole. The Corridor has a high concentration of low-income, minority, transit-dependent residents. More than 49 percent of all Corridor households are designated as low income. In addition, 16 percent of all Corridor households do not have access to an automobile, compared to 8 percent in the County's urbanized area. Forecasts show a growing transit-dependent population, with a projected 55 percent increase in Corridor residents that rely on, or will rely on the area's transit system. The Project will provide significant improvements for low-income, elderly and transit-dependent persons living in the Corridor area.

2. Implementation of the Project will result in a reduction of vehicle miles per day and reduction of auto air pollutants.
3. The Project will relieve congestion on the already over capacity I-405 San Diego and the I-10 Santa Monica Freeways and surrounding major thoroughfares. In addition, it will reduce the parking demands in the Westside area by providing an alternative means of transportation, competitive in rush-hour travel times with the automobile.
4. The Project will be a major link in the existing county-wide rail transit system, and will thereby provide alternative means of transportation during fuel crises and increased future traffic congestion.
5. The Project will meet the need for improved transit service of the significant transit-dependent population within the Project area.

It is recommended that based on the above evidence, the Board find and determine that the public interest and necessity require the Project.

**B The Project is planned or located in the manner that will be most compatible with the greatest public good and least private injury.**

On September 11, 2009, a Draft Environmental Impact Statement / Draft Environmental Impact Report (DEIS/DEIR) was circulated and reviewed by interested and concerned parties, including private citizens, community groups, the business community, elected officials and public agencies. Public hearings were held to solicit citizen and agency comments. A total of four alternatives, including two build alternatives, were presented in the September 2009 DEIS/DEIR. On December 20, 2009, the Board adopted the Light Rail Transit (LRT) Alternative as the Locally Preferred Alternative (LPA), after review and consideration of the comments received from circulation of the 2009 DEIS/DEIR. The Board certified the FEIR on September 22, 2011. A Record of Decision was received from the Federal Transit Administration on December 30, 2011.

The Corridor has some of the highest population and employment density in the Southern California region, as well as the highest proportion of transit ridership. No significant expansion of existing freeway and street networks is planned to accommodate this growth. During various community meetings, the residents of the Corridor area expressed their need for improved transit service because many are transit-dependent and need better access to the region's educational, employment, and cultural opportunities. The LPA addresses those needs and moves more people in a way that is energy efficient and with the least environmental impact.

The Project is a LRT dual-track alignment, which will extend from the existing Metro Exposition Line at Crenshaw and Exposition Boulevards. The LRT line will travel 8.5 miles to the Metro Green Line Aviation/LAX Station and will serve the cities of Los Angeles, Inglewood, Hawthorne and El Segundo and portions of unincorporated Los Angeles County. The project includes six stations and two optional stations:

- Crenshaw / Exposition
- Crenshaw / Martin Luther King Jr.
- Leimert Park (optional)
- Crenshaw / Slauson
- Florence / West
- Hindry (optional)
- Aviation / Century

The overall Project will cause private injury, including the displacement or relocation of certain owners and users of private property. The Property under consideration as part of this Resolution of Necessity will not cause such displacement. Moreover, no other alternative locations for the Project provide greater public good with less private injury. Therefore, the Project is planned or located in the manner that will be most compatible with the greatest public good and the least private injury.

Due to its bulk, the FEIS/FEIR is not physically included in the Board's agenda packet for this public hearing. However, the FEIS/FEIR documents should be considered in connection with this matter. It is recommended that, based upon the foregoing, the Board find and determine that the Project is planned or located in the manner that will be most compatible with the greatest public good and the least private injury.

**C. The Property is necessary for the Project.**

The Property consists of a 162 square foot permanent easement and a 50 square foot temporary construction easement in a portion of property commonly known as 6700 Crenshaw Blvd., in the city of Los Angeles. The Property is necessary to make street modifications to the intersection of Crenshaw Blvd. and 67<sup>th</sup> Street. Because there are multiple other parties claiming an interest in the Property and/or have a lien encumbering said Property, METRO has not been able to reach a negotiated agreement. Therefore, acquisition of the Property through eminent domain is necessary in order to maintain the Project schedule and to obtain clear title. The property interest is depicted in the legal description and plat map attached as exhibits to the Proposed Resolution of Necessity.

Staff recommends that the Board find that the acquisition of the Property is necessary for the Project.

**D. Offers were made in compliance with Government Code Section 7267.2.**

California Code of Civil Procedure Section 1245.230 requires that a Resolution of Necessity contain a declaration that the governing body has found and determined that either the offer required by Section 7267.2 of the California Government Code has been made to the owner(s) of record, or the offer has not been made because the owner(s) cannot be located with reasonable diligence.

California Government Code Section 7267.2 requires that an offer be made to the owner or to the owner(s) of record and in an amount which the agency believes to be just compensation. The amount must not be less than the agency's approved appraisal of the fair market value of the property. In addition, the agency is required to provide the owner(s) with a written statement of, and summary of the basis for, the amount it established as just compensation.

Staff has taken the following actions as required by California law for the acquisition of the Property:

1. Obtained an appraisal to determine the fair market value of the Property, which included consideration of any immovable fixtures and equipment as appropriate;
2. Reviewed and approved the appraisal, and established the amount it believes to be just compensation;
3. Determined the owner(s) of the Property by examining the county assessor's record and the title report;
4. Made a written offer to the owner(s) for the full amount of just compensation - which was not less than the approved appraised value; and
5. Provided the Owner with a written statement of, and summary of the basis for, the amount established as just compensation with respect to the foregoing offer.

It is recommended that the based on the above evidence, the Board find and determine that the offer required by Section 7267.2 of the California Government Code has been made to the owner(s) of record.

**E. The environmental review is consistent with the California Environmental Quality Act.**

The required environmental review of the Project was completed and certified by the Board. On September 22, 2011, the Board certified the FEIS/FEIR. A Record of Decision was received from the Federal Transit Administration in December of 2011. The FEIS/FEIR documents were consistent with the California Environmental Quality Act Guidelines.

**CONCLUSION**

Staff recommends that the Board approve the Resolution of Necessity.



**RESOLUTION OF THE  
LOS ANGELES COUNTY METROPOLITAN TRANSPORTATION AUTHORITY  
DECLARING CERTAIN REAL PROPERTY NECESSARY FOR PUBLIC PURPOSES  
AND AUTHORIZING THE ACQUISITION THEREOF  
(CRENSHAW / LAX TRANSIT CORRIDOR PROJECT  
PARCEL CR-2901 & CR-2901-1)**

THE LOS ANGELES COUNTY METROPOLITAN TRANSPORTATION  
AUTHORITY HEREBY FINDS, DETERMINES, AND RESOLVES AS FOLLOWS:

Section 1.

THE LOS ANGELES COUNTY METROPOLITAN TRANSPORTATION  
AUTHORITY ("METRO") is a public entity organized and existing pursuant to Chapter 2 of  
Division 12 of the California Public Utilities Code (commencing with Section 130050).

Section 2.

The property interest described hereinafter is to be taken for public use, namely, for  
public transportation purposes and all uses necessary, incidental or convenient thereto,  
and for all public purposes pursuant to the authority conferred upon the Board to acquire  
property by eminent domain by California Public Utilities Code Sections 30000-33027,  
inclusive, and particularly Section 30503 and 30600, Sections 130000-132650, inclusive,  
and particularly Sections 130051.13, 130220.5, and 132610, Code of Civil Procedure  
Sections 1230.010-1273.050, inclusive, and particularly Sections 1240.510 and 1240.610,  
and Article I, Section 19 of the California Constitution.

Section 3.

The property interest to be acquired consists of a permanent easement and a  
temporary construction easement as designated below, and as described more specifically  
in the exhibits attached hereto (hereinafter, the "Property"), all of which are incorporated  
herein by this reference:

<b>METRO Parcel Number</b>	<b>Assessor's Parcel Number</b>	<b>Parcel Address</b>	<b>Property Owner</b>	<b>Purpose of Acquisition</b>	<b>Property Interest(s) Sought - See Exhibit:</b>
CR-2901 & CR-2901-1	4006-025-032	6700 Crenshaw Blvd., Los Angeles, CA	Noel Dias, Michael Davidyan	Street realignment/modifications	Permanent Easement and Temporary Construction Easement – See Exhibit 1

METRO's acquisition of the above property interests is subject to the following limitation:

Construction of temporary or permanent improvements will not adversely impact the normal operations of surface traffic, or performance of utilities in the Project area. During construction, reasonable access to businesses and residences will be maintained at all times.

Section 4.

(a) The acquisition of the above-described Property is necessary for the development, construction, operation, and maintenance of the Crenshaw / LAX Transit Corridor Project ("Project");

(b) The environmental impacts of the Project were evaluated in the Final Environmental Impact Statement/Final Environmental Impact Report (FEIS/FEIR), which was certified by the Board on September 22, 2011. The Board found that in accordance with the California Environmental Quality Act (CEQA) Guidelines, Section 15162, no subsequent or supplemental Environmental Impact Report is required for the Project, and the FEIS/FEIR documents are consistent with CEQA; and

(c) The Board has reviewed and considered the FEIS/FEIR, before and as part of the process of determining whether to acquire the above-referenced Property.

Section 5.

The Board hereby declares that it has found and determined each of the following:

(a) The public interest and necessity require the proposed Project;

(b) The proposed Project is planned or located in the manner that will be most compatible with the greatest public good and the least private injury;

(c) The Property sought to be acquired, which has been described herein, is necessary for the proposed Project; and

(d) The offer required by Section 7267.2 of the Government Code has been made to the owner(s) of record.

Section 6.

Pursuant to Sections 1240.510 and 1240.610 of the Code of Civil Procedure, to the extent that the Property is already devoted to a public use, the use to which the Property is to be put is a more necessary public use than the use to which the Property is already devoted, or, in the alternative, is a compatible public use which will not unreasonably interfere with or impair the continuance of the public use to which the Property is already devoted.

Section 7.

That notice of intention to adopt this resolution was given by first class mail to each person whose Property is to be acquired by eminent domain in accordance with Section 1245.235 of the Code of Civil Procedure and a hearing was conducted by the Board on the matters contained herein.

Section 8.

Legal Counsel is hereby authorized and directed to take all steps necessary to commence legal proceedings, in a court of competent jurisdiction, to acquire the Property described above by eminent domain. Counsel is also authorized and directed to seek and obtain an Order for Prejudgment Possession of said Property in accordance with the provisions of the eminent domain law and is directed that the total sum of probable just compensation be deposited with the State Treasurer or the Clerk of the Superior Court. Counsel may enter into stipulated Orders for Prejudgment Possession and/or Possession and Use Agreements, where such agreements constitute the functional equivalent of an Order for Prejudgment Possession. Counsel is further authorized to correct any errors or to make or agree to any non-material changes to the legal description of the real property that are deemed necessary for the conduct of the condemnation action or other proceedings or transactions required to acquire the Property.

Counsel is also authorized to reduce or modify the extent of the interests or property to be acquired so as to reduce the compensation payable in the action where such change would not substantially impair the construction and operation for the project for which the real property is being acquired.

Counsel is further authorized to compromise and settle such eminent domain proceedings, if such settlement can be reached, and in that event, to take all necessary action to complete the acquisition, including stipulations as to judgment and other matters, and causing all payments to be made. Counsel is further authorized to associate with, at its election, a private law firm for the preparation and prosecution of said proceedings.

I, MICHELLE JACKSON, Secretary of the Los Angeles County Metropolitan Transportation Authority, do hereby certify that the foregoing Resolution was duly and regularly adopted by a vote of two-thirds of all the members of the Board of the Metropolitan Transportation Authority at a meeting held on the 27<sup>th</sup> day of July 2017.

\_\_\_\_\_  
MICHELLE JACKSON  
METRO Secretary

Date: \_\_\_\_\_

**ATTACHMENTS**

1 - Exhibit "1" – Parcel Legal & Plat

**EXHIBIT 1**

**EXHIBIT "A"**

**LEGAL DESCRIPTION FOR PARTIAL ACQUISITION PURPOSES  
PARCEL NUMBER CR-2901**

THAT PORTION OF LOTS 577 AND 580 OF HYDE PARK TRACT, IN THE CITY OF LOS ANGELES, COUNTY OF LOS ANGELES, STATE OF CALIFORNIA, AS PER MAP RECORDED IN BOOK 14 PAGE 21 OF MISCELLANEOUS RECORDS, IN THE OFFICE OF THE COUNTY RECORDER OF SAID COUNTY, DESCRIBED AS FOLLOWS:

**BEGINNING** AT THE NORTHWESTERLY CORNER OF LOT 577, SAID POINT ALSO BEING THE INTERSECTION OF THE SOUTHERLY RIGHT-OF-WAY LINE OF 67<sup>TH</sup> STREET (FORMERLY KNOWN AS FLOWER STREET), 60 FEET WIDE, WITH THE EASTERLY RIGHT-OF-WAY LINE OF CRENSHAW BOULEVARD (FORMERLY KNOWN AS GRAND AVENUE), 80 FEET WIDE, AS SHOWN ON AFOREMENTIONED TRACT MAP; THENCE ALONG SAID SOUTHERLY LINE N89°40'46"E 18.00 FEET; THENCE DEPARTING SAID SOUTHERLY LINE S45°02'42"W 25.62 FEET TO SAID EASTERLY LINE; THENCE ALONG SAID EASTERLY LINE N00°24'39"E 18.00 FEET TO THE **POINT OF BEGINNING**.

CONTAINS: 162 SQUARE FEET.

NOTE:

THIS LEGAL DESCRIPTION WAS NOT PREPARED FOR ANY PURPOSE THAT WOULD BE IN VIOLATION OF THE STATE OF CALIFORNIA SUBDIVISION MAP ACT OR LOCAL ORDINANCES OF THE GOVERNING BODY HAVING JURISDICTION.

PREPARED BY:

*Stephanie A. Wagner*  
STEPHANIE A. WAGNER, P.L.S. 5752

*June 20, 2012*  
DATE:



EXHIBIT "A"

LEGAL DESCRIPTION FOR TEMPORARY CONSTRUCTION EASEMENT  
PARCEL NUMBER CR-2901-1

THAT PORTION OF LOT 577 OF HYDE PARK TRACT, IN THE CITY OF LOS ANGELES, COUNTY OF LOS ANGELES, STATE OF CALIFORNIA, AS PER MAP RECORDED IN BOOK 14 PAGE 21 OF MISCELLANEOUS RECORDS, IN THE OFFICE OF THE COUNTY RECORDER OF SAID COUNTY, DESCRIBED AS FOLLOWS:

**COMMENCING** AT THE NORTHWESTERLY CORNER OF LOT 577, SAID POINT BEING ALSO THE INTERSECTION OF THE SOUTHERLY LINE OF 67<sup>TH</sup> STREET (FORMERLY KNOWN AS FLOWER STREET), 60 FEET WIDE, WITH THE EASTERLY RIGHT-OF-WAY LINE OF CRENSHAW BOULEVARD (FORMERLY KNOWN AS GRAND AVENUE), 80.00 FEET WIDE, AS SHOWN ON AFOREMENTIONED TRACT MAP; THENCE ALONG SAID SOUTHERLY LINE, N89°40'46"E 16.78 FEET **TO THE TRUE POINT OF BEGINNING**; THENCE LEAVING SAID SOUTHERLY LINE, S45°03'12"W 21.03 FEET; THENCE N89°35'21"W 2.00 FEET TO SAID EASTERLY LINE OF CRENSHAW BOULEVARD; THENCE ALONG SAID EASTERLY LINE, S00°24'39"W 2.00 FEET; THENCE LEAVING SAID EASTERLY LINE S89°35'21"E 2.84 FEET; THENCE N45°03'12"E 23.89 FEET TO SAID SOUTHERLY LINE OF 67<sup>TH</sup> STREET ; THENCE ALONG SAID SOUTHERLY LINE S89°40'46"W 2.85 FEET **TO THE TRUE POINT OF BEGINNING.**

CONTAINS: 50 SQUARE FEET, MORE OR LESS.

NOTE:

THIS LEGAL DESCRIPTION WAS NOT PREPARED FOR ANY PURPOSE THAT WOULD BE IN VIOLATION OF THE STATE OF CALIFORNIA SUBDIVISION MAP ACT OR LOCAL ORDINANCES OF THE GOVERNING BODY HAVING JURISDICTION.

PREPARED BY:

*Stephanie A. Wagner*  
STEPHANIE A. WAGNER, P.L.S. 5752

*Sep. 28, 2015*  
DATE:



## EXHIBIT "B"

Grantor: NOEL DIAZ, ALSO KNOWN AS NOEL STONE Description: PORTION OF LOTS 577 AND 580 OF HYDE PARK TRACT, IN THE CITY OF LOS ANGELES, COUNTY OF LOS ANGELES, STATE OF CALIFORNIA, AS PER MAP RECORDED IN BOOK 14 PAGE 21 OF MISCELLANEOUS RECORDS Title Report: OLD REPUBLIC TITLE COMPANY NO. 2476019278-52 Assessor's Ref: 4006-025-032	THE DATA SHOWN ON PLAT ARE BASED ON FIELD SURVEY PREPARED BY WAGNER ENGINEERING & SURVEY, INC. DATED JUNE 2011 - JUNE 2012. BEARING AND DISTANCES ARE BASED ON CALIFORNIA COORDINATE SYSTEM NAD 83 ZONE 5 COORDINATES OBTAINED FROM CALIFORNIA H.P.G.N.						
ROW Ref: R-129	<table border="1" style="width: 100%; border-collapse: collapse;"> <thead> <tr> <th style="width: 10%;">No.</th> <th style="width: 10%;">Date</th> <th style="width: 80%;">Revision Description</th> </tr> </thead> <tbody> <tr> <td> </td> <td> </td> <td> </td> </tr> </tbody> </table>	No.	Date	Revision Description			
No.	Date	Revision Description					

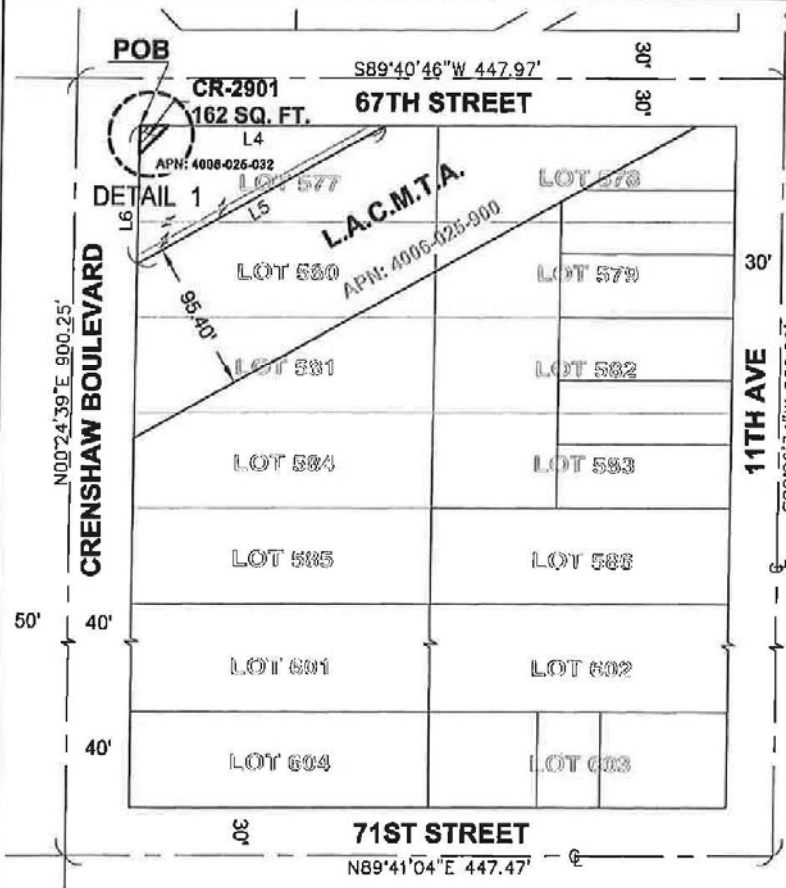

LINE TABLE		
LINE	BEARING	LENGTH
L1	N89°40'46"E	18.00'
L2	S45°02'42"W	25.62'
L3	N00°24'39"E	18.00'
L4	N89°40'46"E	155.61'
L5	S60°48'30"W	178.96'
L6	N00°24'39"E	86.42'

**LEGEND:**  
 PA = PARTIAL ACQUISITION  
 POB = POINT OF BEGINNING  
 APN = ASSESSOR'S PARCEL NUMBER  
 LACMTA = LOS ANGELES COUNTY METROPOLITAN TRANSPORTATION AUTHORITY

THIS EXHIBIT IS MADE PART OF THE LEGAL DESCRIPTION

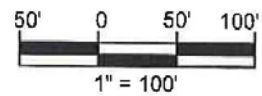
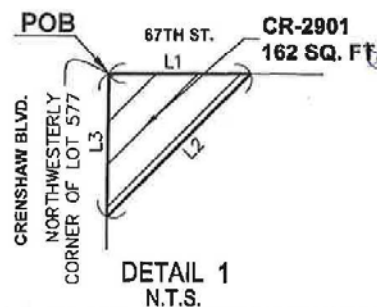

TOTAL AREA OF PROPERTY	CR-2901	REMAINDER PARCEL AREA	ESTATE
6,723 SQ. FT.	162 SQ. FT.	6,561 SQ. FT.	PA
APPROVED BY: <i>[Signature]</i> 10/19/15 PROJECT MANAGER DATE		CRENSHAW/LAX TRANSIT CORRIDOR PROJECT	
PREPARED BY: <i>[Signature]</i> WAGNER ENGINEERING & SURVEY, INC. 10933 Parklawn Dr., Suite 100 Northridge, CA 91324 CHECKED BY: LS: 5752			
Metro		DATE: 06/20/12 SCALE: 1"=100' REV. No. DATE: REV. No. DATE: PARCEL No. CR-2901	
Hatch Mott MacDonald		WAGNER ENGINEERING & SURVEY, INC.	

## EXHIBIT "B"

Grantor: NOEL DIAS		THE DATA SHOWN ON PLAT ARE BASED ON FIELD SURVEY PREPARED BY WAGNER ENGINEERING & SURVEY, INC. DATED JUNE 2011 - JUNE 2012. BEARING AND DISTANCES ARE BASED ON CALIFORNIA COORDINATE SYSTEM NAD 83 ZONE 8 COORDINATES OBTAINED FROM CALIFORNIA H.P.G.N.		
Description: PORTION OF LOTS 577 AND 580 OF HYDE PARK TRACT, IN THE CITY OF LOS ANGELES, COUNTY OF LOS ANGELES, STATE OF CALIFORNIA, AS PER MAP RECORDED IN BOOK 14 PAGE 21 OF MISCELLANEOUS RECORDS				
Title Report: ORANGE COAST TITLE COMPANY ORDER NO. 140-1545149-32				
Assessor's Ref: 4006-025-032	ROW Ref: R-12B & R-129	No.	Date	Revision Description

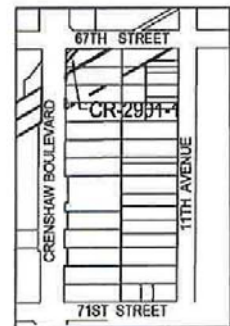
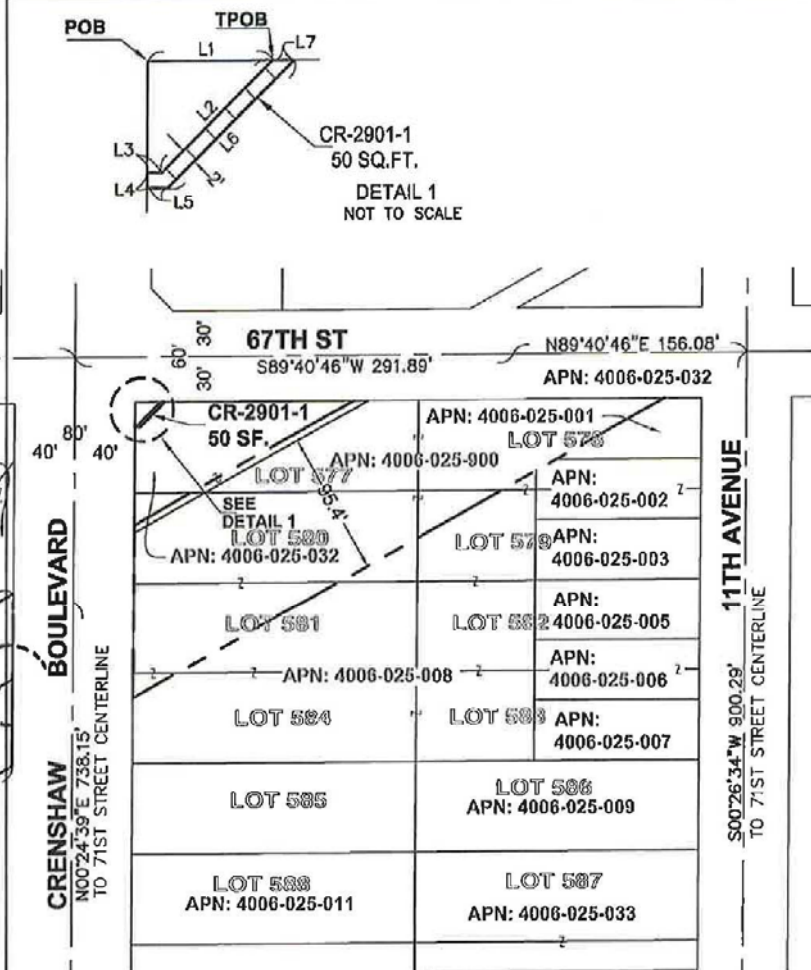

VICINITY MAP  
NOT TO SCALE

LINE TABLE		
LINE	BEARING	LENGTH
L1	N89°40'46"E	16.78'
L2	S45°03'12"W	21.03'
L3	N89°35'21"W	2.00'
L4	S00°24'39"W	2.00'
L5	S89°35'21"E	2.84'
L6	N45°03'12"E	23.89'
L7	S89°40'46"W	2.85'



**LEGEND:**  
 APN = ASSESSOR'S PARCEL NUMBER  
 POC = POINT OF COMMENCEMENT  
 TPOB = TRUE POINT OF BEGINNING  
 TCE = TEMPORARY CONSTRUCTION EASEMENT

**NOTE:**  
 THIS EXHIBIT IS MADE PART OF THE LEGAL DESCRIPTION

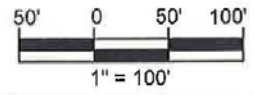

TOTAL AREA OR PROPERTY	CR-2901-1	REMAINDER PARCEL AREA	ESTATE	
6,723 SQ. FT.	50 SQ. FT.	6,673 SQ. FT.	TCE	
	APPROVED BY: <i>[Signature]</i> 10/19/15 PROJECT MANAGER DATE	CRENSHAW/LAX TRANSIT CORRIDOR PROJECT		
	PREPARED BY: Stephanie Wagner CHECKED BY: LS: 5752			DATE: 09/28/15
				SCALE: 1"=100'
				REV. No. DATE:
		REV. No. DATE:	PARCEL No. CR-2901-1	