



**Board Report**

**File #:** 2019-0197, **File Type:** Contract

**Agenda Number:** 39.

**REVISED**  
**REGULAR BOARD MEETING**  
**APRIL 25, 2019**

**SUBJECT: METRO GOLD LINE INTERSTATE 210 BARRIER REPLACEMENT**

**ACTION: APPROVE RECOMMENDATIONS**

**RECOMMENDATION**

CONSIDER:

- A. INCREASING Design Life-of-Project (LOP) Budget for Metro Gold Line Interstate 210 Barrier Replacement, (CP Number 405581) by \$11,463,026, increasing the LOP budget from \$11,078,366 to \$22,541,392; and
- B. AUTHORIZING the Chief Executive Officer to execute Contract Modification No. 1 to the On-Call Highway Program Project Delivery Support Services Contract Nos. AE30673000, AE30673001, AE30673002 with AECOM, CH2M Hill, and Parsons Transportation Group, respectively, in the amount not-to exceed \$11,000,000 increasing the total contract value from \$30,000,000 to \$41,000,000.

(CARRIED-OVER FROM MARCH BOARD MEETING)

**ISSUE**

Since the opening of the Metro Gold Line, there have been ten accidents in which mostly high profile vehicles, traveling on the 210 Freeway, have entered into Metro's operating Right-of-Way. The latest incident occurred on Thursday, November 22, 2018. During the incident, a tractor trailer breached the existing concrete barrier causing damage to the Gold Line system and resulting in a major disruption. Staff has been working on developing a design for barrier improvements for the Pasadena Gold Line to effectively mitigate the risks of future breaches into Metro's Gold Line Right-of-Way. Once the barrier improvements design is completed and approved by Caltrans, Metro will procure a construction contract for installation of the improvements.

The Design LOP budget was approved at the May 2016 board for an amount of \$11,078,366. The original design contract was awarded to CH2M Hill Inc. (now a part of Jacobs) for an initial value of

\$4,799,967. Two modifications to this contract were made that brought the total value of the contract to \$5,233,277.

The environmental impact and disruption to Metro Gold Line operations during construction of this project are much larger than initially anticipated. To effectively address all the environmental issues and provide a complete design that accounts for Metro rail operation, an adjustment to the initial LOP funding needs to be made to cover the increased costs through final design.

## **BACKGROUND**

The original project was initially scoped and considered as a relatively simple and straightforward barrier replacement project. It was assumed that this project would be easily cleared environmentally because all the anticipated work was going to be within the prism of the roadway on State or public right-of-way. Also, no significant impacts or resource agency permits were expected. However, as the design development phase proceeded, information from the field began to greatly complicate the project.

For the majority of the project limits, the tight spatial constraint of the project site will require the closure of the HOV lane on the I-210 freeway and single tracking of the Gold Line during the removal and replacement of the existing median barrier. The non-standard features of the existing freeway had to be reviewed and current mitigation measures needed to be reevaluated to determine if they were still effective. For example, some portions of the I-210 freeway currently do not meet the standard stopping site distance requirement. This non-standard feature is currently being mitigated by tail light requirements (a requirement that following vehicles can observe the tail lights on a preceding vehicle to ensure adequate braking distance). By increasing the height of the median barrier, the project would no longer meet the current tail light requirement and a new mitigation measure for stopping site distance must be studied and implemented. Also, the design was obliged to comply with some of the new code requirements and where possible add new features such as lighting at each HOV egress and ingress locations.

Since the HOV lane of the I-210 freeway will be closed for a significant length of time during construction of this project, traffic diverting from I-210 mainline onto local streets is expected. To better understand the traffic and environmental impacts imposed by this project, a specialized microsimulation traffic analysis and a focused air quality study during construction were added to the project's scope of work. The tight spatial constraints and the need to design the barriers for the highest crash worthiness required the development of more complicated non-standard barrier details which will require Caltrans' approval.

## **DISCUSSION**

We have presented a Board Box dated November 16, 2018 detailing the project progress. In that

progress report, we also outlined the next steps necessary to successfully complete the project. There are various factors that contributed to contract changes and increased costs and the need to increase the design LOP. The project was initially scoped for somewhat simple barrier replacement. The scope of design and environmental studies were well coordinated with Caltrans prior to establishing a LOP.

Neither Metro nor Caltrans foresaw the environmental issues and design difficulties that the project is currently facing. These difficulties include, large freeway traffic disruptions during construction that give rise to delays beyond acceptable limits, resulting in diversion of traffic onto the local streets which causes issues with air quality and noise, addressing existing non-standard freeway features, obtaining approval for use of stronger non-standard barriers, and impacting Metro's operations during construction of the project.

Metro and Caltrans have agreed to divide the project into two pieces. This will allow the portion with lesser environmental issues to move forward at a faster pace towards final design while the environmental issues on the other portion are being addressed. Due to the urgency of the project, the design has been moving forward at risk, meaning that the environmental studies and the final design are being done concurrently. Therefore, now that the project is divided into two pieces, some of the work that has already been done needs to be revised, impacting the cost of the project.

Currently about \$3.9 million is still remaining from the original LOP. This contract was awarded to CH2M as an on-call contract (Contract No. PS4730-3070) and has since expired. No additional change orders can be issued to CH2M through this contract. Staff recommends utilizing the On-Call Highway Program Project Delivery Support Services contract (Contract No. AE30673001) approved by the Board on 06/27/2017. CH2M is one of the consultants that competed and was selected to perform engineering services under that contract. In order to be responsive to this high priority and urgent project and provide continuity to the project, we elected to use this Metro contract with CH2M to continue the design.

### **DETERMINATION OF SAFETY IMPACT**

This Board's decision to approve this Project is paramount to ensuring public safety along the Metro Gold Line I-210 corridor.

Completion of this project will be an important step in improving safety and reducing the likelihood of future breaches into Metro's Gold Line Operational Right-of- Way. The improvements described in this project are necessary for public safety.

### **FINANCIAL IMPACT**

The funds for FY19 is included in cost center 8510 - Construction Procurement, under project number 405581 - I-210 Barrier Replacement. Since this is a multi-year project, the Project Manager,

---

the cost center manager and Chief Program Management Officer will be accountable for budgeting the cost in future years.

### Impact to Budget

The funding source for this action will come from Proposition C 25% (PC25%) as a result of work scope aligned with highway related improvements. This fund source is not eligible for operating or capital improvements on bus and rail. No other fund sources were considered.

## **IMPLEMENTATION OF STRATEGIC PLAN GOALS**

By supporting the recommendation to increase the LOP budget of the I-210 Barrier Replacement Project, the Board is supporting Metro's strategic plan goal 1 which promotes trip reliability, reduces trip disruptions as well as delivery of world-class transit service by ensuring our transit assets are in a state of good repair. Each time the median barrier was breached, Metro's Gold Line operations and ridership were affected. The I-210 Barrier Replacement Project will eliminate the likelihood of a freeway vehicle breaching the median barrier and affecting Gold Line operations in the future.

## **ALTERNATIVES CONSIDERED**

The following alternatives were considered:

1. Keeping the value of LOP at current level will not provide the necessary funds to complete the design of this project. The existing barrier, which does not prevent intrusion of high profile vehicles, will remain in place. This alternative is not recommended since, on an average basis, we experience two vehicle intrusions per year into Metro operating right of way.
2. Awarding the remaining portion of the work to a firm other than CH2M/Jacob or issuance of a new contract other than the Highway Program On-Call Services Contract. This will require procurement of a new contract. This alternative is not recommended because it will delay the project considerably either because of the time that it will take to procure a new contract or the time it would take for a new team to learn about the project before continuing with the current design.

## **NEXT STEPS**

Upon Board approval, staff will execute Contract Modification No. 1 to the On-Call Highway Program Project Delivery Support Services contracts with CH2M Hill, AECOM and Parsons Transportation Group and issue a Task Order to CH2M Hill to continue design of the project and obtain Caltrans approval for the replacement the existing barrier along the median of I-210. Staff will report monthly project progress to the Board.

**ATTACHMENTS**

- Attachment A - Procurement Summary
- Attachment B - Contract Modification/Change Order Log
- Attachment C - DEOD Summary
- Attachment D - Funding/Expenditure Plan

Prepared by:

Androush Danielians, Executive Officer (213) 922-7598

Reviewed by:

Richard Clarke, Chief Program Management Officer (213) 922-7557

Debra Avila, Chief Vendor/Contract Management Officer (213) 418-3051

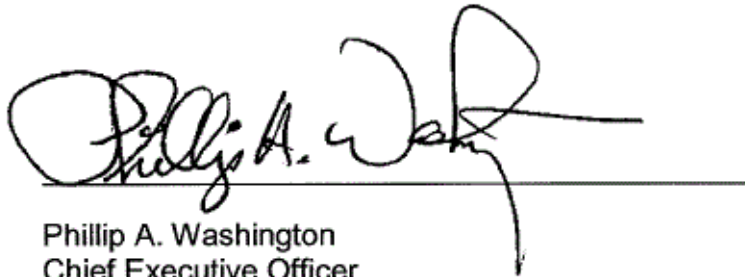

Phillip A. Washington  
Chief Executive Officer

## PROCUREMENT SUMMARY

## ON-CALL HIGHWAY PROGRAM PROJECT DELIVERY SUPPORT SERVICES

## AE30673000/AE30673001/AE30673002

1.	<b>Contract Number:</b> AE30673000/AE30673001/AE30673002		
2.	<b>Contractor:</b> AECOM, CH2M Hill Inc., Parsons Transportation Group		
3.	<b>Mod. Work Description:</b> Replace existing I-210 non-standard barriers with taller barriers capable to withstanding crash loads equivalent to TL-5 load rated barriers.		
4.	<b>Contract Work Description:</b> On-Call Highway Program Project Delivery Support Services		
5.	<b>The following data is current as of:</b> March 7, 2019		
6.	<b>Contract Completion Status</b>		<b>Financial Status</b>
	<b>Contract Awarded:</b>	June 27, 2017	<b>Contract Award Amount:</b> \$30,000,000
	<b>Notice to Proceed (NTP):</b>	N/A	<b>Total of Modifications Approved:</b> \$0.00
	<b>Original Complete Date:</b>	June 21, 2020	<b>Pending Modifications (including this action):</b> \$11,000,000
	<b>Current Est. Complete Date:</b>	June 21, 2020	<b>Current Contract Value (with this action):</b> \$41,000,000
7.	<b>Contract Administrator:</b> Mark T. Penn		<b>Telephone Number:</b> 213.922.1455
8.	<b>Project Manager:</b> Andrroush Danielians		<b>Telephone Number:</b> 213.922.7598

**A. Procurement Background**

This Board Action is to approve Contract Modification No. 1 to the On-Call Highway Program Project Delivery Support Services contracts issued in support of the I-210 Barrier Replacement Program.

This Contract Modification will be processed in accordance with Metro's Acquisition Policy and the contract type is a task order based firm fixed price.

On June 27, 2017, the Board awarded three contracts where work will be authorized through the issuance of separate FFP task orders. The Board approved cumulative total value of the three contracts combined is not-to-exceed \$30,000,000. The contracts were awarded to AECOM Technical Services Inc. (Contract No.

AE30673000), CH2M Hill Inc./Jacobs (Contract No. AE30673001), and Parsons Transportation Group, Inc. (Contract No. AE30673002). CH2M Hill Inc. was the prime contractor on the I-210 Barrier Replacement Program and has, to date, provided a 60% complete design drawing package on the project.

**B. Cost Analysis**

Work will be performed through the issuance of separate task orders. Proposals submitted for each task order will be subjected to audits, cost analysis, technical analysis, fact finding, and negotiations to determine the fairness and reasonableness of price.

(Refer to Attachment B – Contract Modification/Change Order Log)

## CONTRACT MODIFICATION/CHANGE ORDER LOG

## ON-CALL HIGHWAY PROGRAM PROJECT DELIVERY SUPPORT SERVICES

AE30673000/AE30673001/AE30673002

<b>Mod. No.</b>	<b>Description</b>	<b>Status (approved or pending)</b>	<b>Date</b>	<b>\$ Amount</b>
1	Replace existing I-210 non-standard barriers with taller barriers capable of withstanding crash loads equivalent to TL-5 load rated barriers.	<b>Pending</b>	03/28/19	\$11,000,000
	<b>Modification Total:</b>			<b>\$11,000,000</b>
	<b>Original Contract(s):</b>			<b>\$30,000,000</b>
	<b>Total:</b>			<b>\$41,000,000</b>



**DEOD SUMMARY**

**I-210 Barrier Replacement/AE30673000/AE30673001/AE30673002**

**A. Small Business Participation**

CH2M Hill Inc./Jacobs made a 27% SBE and 3% DVBE commitment. The project is 17% complete and CH2M Hill Inc./Jacobs current SBE/DVBE participation is 0%. CH2M Hill Inc./Jacobs has a current shortfall of 27% SBE and 3% DVBE. CH2M Hill Inc./Jacobs explained that their shortfall is due to only receiving three small task orders to date. CH2M Hill Inc./Jacobs projects that the task order currently being processed will increase their SBE/DVBE participation. The value of these task orders is approximately 3.5% of the total potential value of this overall contract, and CH2M Hill Inc./Jacobs indicated that they would be able to meet the SBE/DVBE commitment with future work. The value of these task orders is approximately 3.5% of the total potential value of this overall contract. CH2M Hill Inc./Jacobs has made a 36.31% SBE and 3.10% DVBE commitment on the pending modification which is projected to increase their SBE/DVBE participation. CH2M Hill Inc./Jacobs indicated that they will meet their SBE/DVBE commitment.

Notwithstanding, Metro Project Managers and Contract Administrators, will work in conjunction with DEOD to ensure that CH2M Hill Inc./Jacobs is on schedule to meet or exceed its DBE commitment. If CH2M Hill Inc./Jacobs is not on track to meet its small business commitment, Metro staff will ensure that CH2M Hill Inc./Jacobs submits an updated mitigation plan. Additionally, key stakeholders associated with the contract have been provided access to Metro’s tracking and monitoring system to ensure that all parties are actively tracking Small Business progress.

<b>Small Business Commitment</b>	<b>27% SBE 3% DVBE</b>	<b>Small Business Participation</b>	<b>0% SBE 0% DVBE</b>
----------------------------------	----------------------------	-------------------------------------	---------------------------

	<b>SBE Subcontractors</b>	<b>% Committed</b>	<b>Current Participation<sup>1</sup></b>
1.	ACT Consulting Engineers, Inc.	TBD	0.00%
2.	AP Engineering & Testing, Inc.	TBD	0.00%
3.	Arrellano Associates, LLC	TBD	0.00%
4.	Epic Land Solutions, Inc.	TBD	0.00%
5.	Geo- Advantec, Inc.	TBD	0.00%
6.	Hout Construction Services, Inc.	TBD	0.00%
7.	Martini Drilling Corporation	TBD	0.00%
8.	Minagar & Associates, Inc.	TBD	0.00%
9.	Pac Rim Engineering, Inc.	TBD	0.00%
10.	Rincon Consultants, Inc.	TBD	0.00%
11.	System Metrics Group, Inc.	TBD	0.00%

12.	Tatsumi & Partners, Inc.	TBD	0.00%
13.	Wagner Engineering & Surveying, Inc.	TBD	0.00%
	<b>Total</b>	<b>27.00%</b>	<b>0.00%</b>

	<b>DVBE Subcontractors</b>	<b>% Committed</b>	<b>Current Participation<sup>1</sup></b>
1.	Virtek Company	3.00%	0.00%
	<b>Total</b>	<b>3.00%</b>	<b>0.00%</b>

<sup>1</sup>Current Participation = Total Actual amount Paid-to-Date to DBE firms ÷ Total Actual Amount Paid-to-date to Prime.

**B. Living Wage and Service Contract Worker Retention Policy Applicability**

The Living Wage and Service Contract Worker Retention Policy is not applicable to this

**C. Prevailing Wage Applicability**

Prevailing Wage requirements are applicable to this project. DEOD will monitor contractors' compliance with the State of California Department of Industrial Relations (DIR), California Labor Code, and, if federally funded, the U S Department of Labor (DOL) Davis Bacon and Related Acts (DBRA). Trades that may be covered include: surveying, potholing, field, soils and materials testing, building construction inspection, construction management and other support trades.

**D. Project Labor Agreement/Construction Careers Policy**

Project Labor Agreement/Construction Careers Policy is not applicable to this Contract. Project Labor Agreement/Construction Careers Policy is applicable only to construction contracts that have a construction contract value in excess of \$2.5 million.

**FUNDING/EXPENDITURE PLAN**

**Project 405581 – Metro Gold Line Interstate 210 Median Barrier Replacement**

Use of Funds	Expended Through FY18	FY19	FY20	Total	Total
Professional Services:					
Final Design Consultant	\$ 4,503,600	\$ 6,676,000	<del>\$ 5,088,700</del> \$ 5,012,700	<del>\$ 16,268,300</del> \$ 16,192,300	72%
Reviews/Coordination (Caltrans)	\$ 962,000	\$ 700,000	\$ 1,030,500	\$ 2,692,500	12%
CMA		\$ 700,000	\$ 456,000	\$ 1,156,000	5%
<b>Total Professional Services</b>	<b>\$ 5,465,600</b>	<b>\$ 8,076,000</b>	<del><b>\$ 6,575,200</b></del> <b>\$ 6,499,200</b>	<del><b>\$ 20,116,800</b></del> <b>\$ 20,040,800</b>	<b>89%</b>
Metro Engineering & Administration	\$ 379,300	\$ 400,000	\$ 670,392	\$ 1,449,692	6%
Contingency	\$ -	\$ 600,000	\$ 450,900	\$ 1,050,900	5%
<b>Total Project Cost</b>	<b>\$ 5,844,900</b>	<b>\$ 9,076,000</b>	<del><b>\$ 7,696,492</b></del> <b>\$ 7,620,492</b>	<del><b>\$ 22,617,392</b></del> <b>\$ 22,541,392</b>	<b>100%</b>
Sources of Funds	Funded Through FY18	FY19	FY20	Total	Total
<b>Prop C 25%</b>	<b>\$ 5,844,900</b>	<b>\$ 9,076,000</b>	<del><b>\$ 7,696,492</b></del> <b>\$ 7,620,492</b>	<del><b>\$ 22,617,392</b></del> <b>\$ 22,541,392</b>	<b>100%</b>
<b>Total Project Funding</b>	<b>\$ 5,844,900</b>	<b>\$ 9,076,000</b>	<del><b>\$ 7,696,492</b></del> <b>\$ 7,620,492</b>	<del><b>\$ 22,617,392</b></del> <b>\$ 22,541,392</b>	<b>100%</b>

Los Angeles County Metropolitan Transportation Authority



# Gold Line I-210 Barrier Replacement Project

*March 28, 2019 Board Presentation*



# Gold Line I-210 Barrier Replacement - Project Limits



## Split into 2 Projects for Expediency

Total Project: Marengo Tunnel to Iconic Bridge

Project 1: Michillinda Avenue to Iconic Bridge

Project 2: Marengo Tunnel to Michillinda Ave.

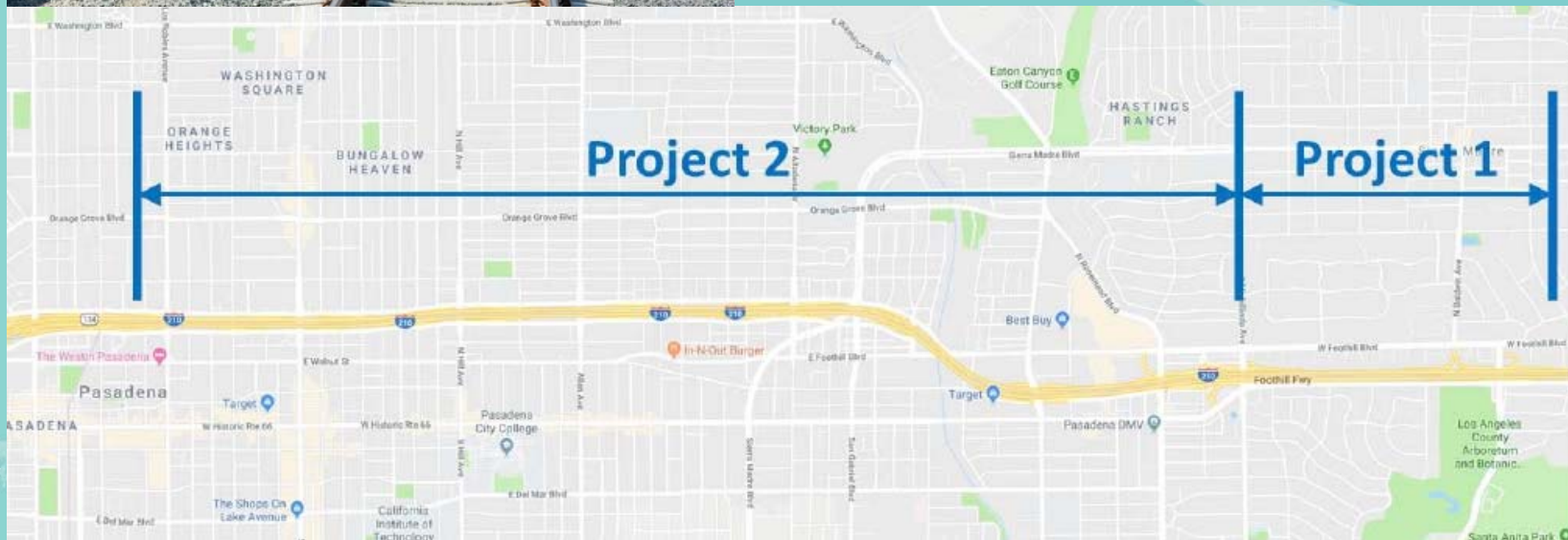

# Gold Line I-210 Barrier Replacement - A Safety Project



**Metro Gold Line: I-210 Median Vehicle Breach Incident Map:**

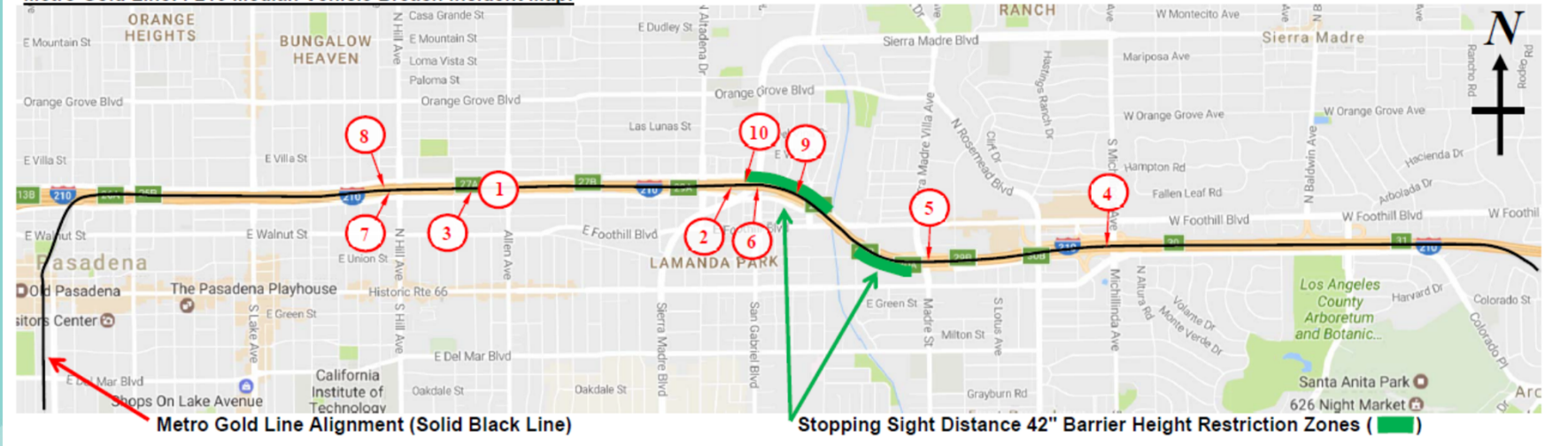

**Gold Line I-210 barriers are being replaced to prevent this from occurring in the future.**



# Gold Line I-210 Barrier Replacement – Existing and Proposed Barrier Configurations

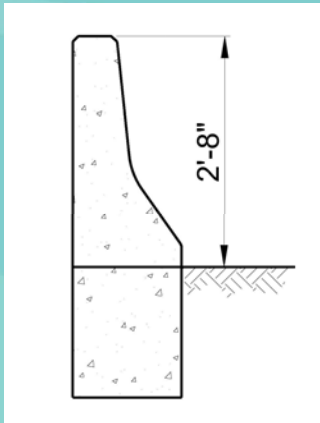

On Ground

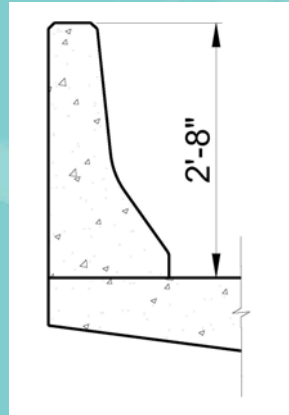

On Bridge

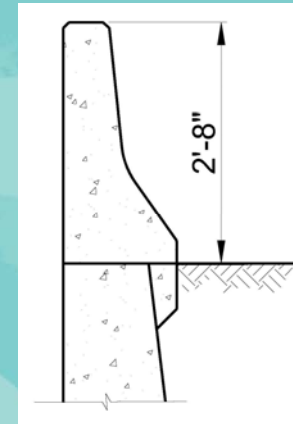

On Retaining Wall

## Existing Barrier Configurations

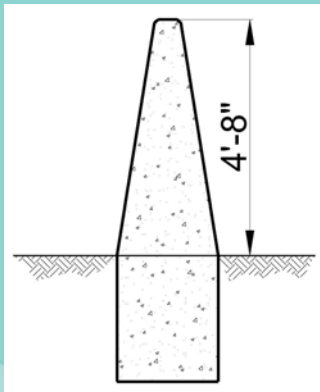

On Ground

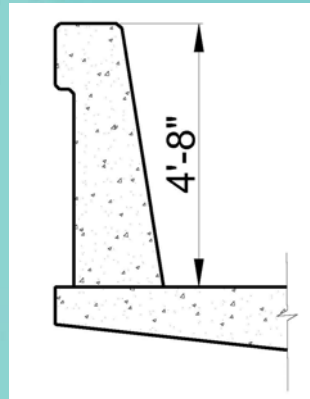

On Bridge

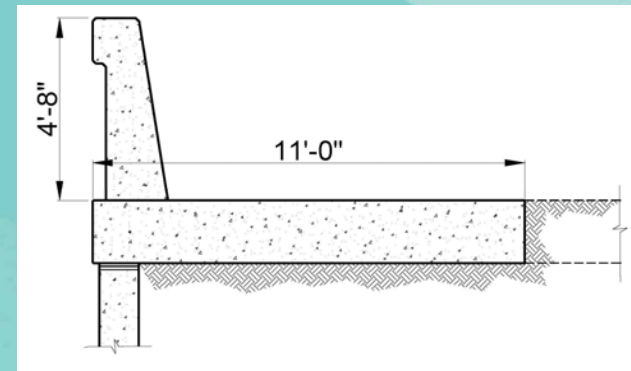

On Retaining Wall



Metro

## Proposed Barrier Configurations

# Gold Line I-210 Barrier Replacement – Addressing the Challenges

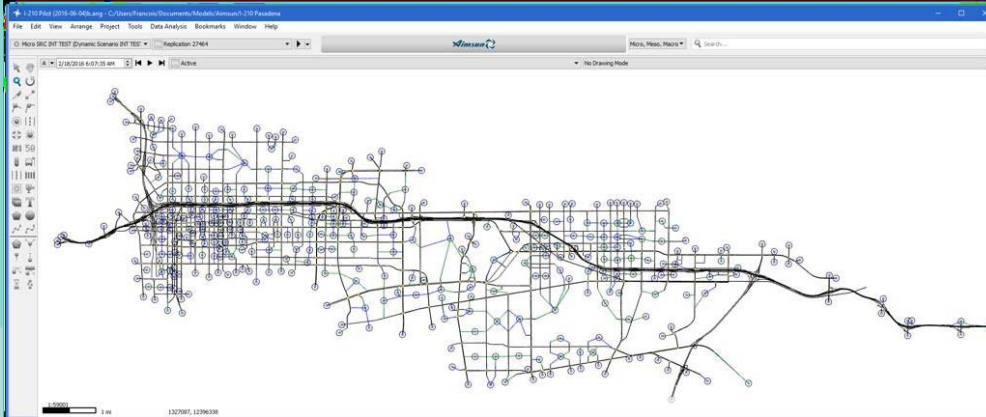

## Optimized Solutions:

- Extremely tight workspace causing HOV lane closure and single tracking for the construction of Project 2; complicating environmental clearance
- Complex traffic study underway to quantify traffic impacts to the freeway and city streets





Thank you

