



Board Report

File #: 2019-0853, File Type: Fare / Tariff / Service Change

Agenda Number: 16.

OPERATIONS, SAFETY, AND CUSTOMER EXPERIENCE COMMITTEE JANUARY 16, 2020

SUBJECT: PUBLIC REVIEW OF NEXTGEN TRANSIT FIRST SERVICE PLAN

ACTION: APPROVE RECOMMENDATION

RECOMMENDATION

CONSIDER:

1. AUTHORIZING the release of the NextGen Draft Transit First Service Plan for public review;
and
2. APPROVING updates to the Transit Service Policy to reflect the NextGen Regional Service Concept

BONIN AMENDMENT: Add a report back from OMB by April 2020 regarding funding options for the capital portion of the NextGen Transit First scenario.

ISSUE

In July 2019, the Metro Board approved the NextGen Regional Service Concept, which is the framework for restructuring Metro's bus routes and schedules for NextGen and includes:

1. Goals and objectives of the new bus network;
2. Measures of success;
3. Route and network design concepts based on public input and data analysis;
4. Framework for balancing tradeoffs that consider Metro's Equity Platform

Staff have updated the Board adopted Transit Service Policy (TSP) to reflect the Regional Service Concept which was used to develop the NextGen draft service plans. This report requests approval of the updates to the TSP and the release of the Draft Transit First Service Plan for public review starting February 2020.

BACKGROUND

In January 2018, Metro began the NextGen Bus Study aimed at reimagining the bus network to be more relevant, reflective of, and attractive to the diverse customer needs within Los Angeles County.

More specifically, the NextGen Bus Study aims to increase transit use within the County over the next decade by retaining current customers and attracting them to ride more often, reclaiming past customers, and recruiting new customers

The NextGen Bus Study is divided into four phases:

1. Conduct market research, travel demand analysis and existing service evaluation to identify areas of success, deficiency, and gaps within the network;
2. Establish a Regional Service Concept to guide the development of the NextGen Service Plan;
3. Develop the NextGen Service Plan, including routing, stop spacing, frequency, span of service, and coordination with municipal operators;
4. Implement the NextGen Service Plan through extensive engagement and public hearing process.

The first phase of the project consisted of understanding customers and what they want in a bus system. A significant effort went into understanding overall travel patterns within LA County using cell phone location data as well as an analysis of regional TAP use across 26 transit operators. A comprehensive evaluation of the existing bus network (Attachment A), broken down by routes and segments by time of day, was conducted to understand current successes as well as deficiencies and gaps in service. Significant public engagement was conducted with customers and residents with over 10 million touchpoints throughout the County via online engagement, print advertising, pop-up sessions, 260+ stakeholder and community meetings, on-board bus canvassing, and at 20 interactive public workshops to validate the market research, receive comments, and to gain valuable insight into route and area specific concerns and recommendations.

Based on the research and outreach conducted in Phase I, the Board adopted the Regional Service Concept in July 2019 which established:

1. Goals and objectives of the new bus network;
2. Measures of success;
3. Route and network design concepts based on public input and data analysis;
4. Framework for balancing tradeoffs that consider Metro's Equity Platform

This Regional Service Concept provides a planning framework to redesign the bus network.

Transit Service Policy

The policy choices set by the NextGen Regional Service Concept have been incorporated into an updated Transit Service Policy. This Board adopted document translates policies and objectives into criteria and thresholds to be used in designing and managing the Metro bus network. In addition to the changes from NextGen, other changes to the document have been incorporated to reflect the updated Title VI program, including service standards, definitions of what constitute major service changes, and the standards for determining disparate impact on minorities, and disproportionate burden for low income persons.

NextGen Draft Service Plan (Building a World Class Bus System)

In 2018 the Board adopted Metro Vision 2028 as the agency's strategic plan. This plan envisioned

building a World Class Transportation System in which a World Class Bus System is a cornerstone to its success. Building a World Class Bus System requires improving the attractiveness and competitiveness of the bus network. Attractiveness includes addressing issues such as safety and security, cleanliness, comfort, real time arrival information, easy fare payment, wayfinding and signage, and first/last mile access. Competitiveness requires developing a bus network that minimizes the overall travel time to complete a trip compared to the driving alternative. This travel time considers directness of route, access to the bus stop, waiting time, and onboard travel time.

NextGen's primary purpose is to improve the competitiveness of the bus network. However, through this process, improvements to certain aspects of attractiveness can also be achieved. The following outlines a strategy for how NextGen will set the foundation for building a World Class Bus System.

Step 1: Reconnect Scenario

Metro currently provides roughly 7 million revenue service hours (RSH) of bus service per year. The first step in creating a World Class Bus System is to redesign the routes and schedules to attract trips where and when there is the greatest market potential. The lessons learned in Phase 1 present a path forward for reinventing the bus network:

- **85% of LA County residents have used transit at least once in the past year**, THEREFORE, we should attempt to maintain coverage throughout the County by minimizing discontinued segments.
- **Fast/Frequent/reliable service is key**, THEREFORE, we need to create a competitive transit network that reduces overall travel time by optimizing all components of the trip, including walking, waiting, and riding.
- **Metro's current system is not always competitive to get people where they want to go**, THEREFORE routing should be adjusted to reflect the key origins and destinations identified in the cell phone location data.
- **The greatest opportunity to grow ridership is between midday & evening when many trips are short distance**, THEREFORE service levels should be improved for midday, evenings and weekends.
- **Need to integrate Metro's Equity Framework into the planning process**, THEREFORE service improvements should be prioritized for equity-focused areas.

A draft service plan has been developed based on the lessons learned to "reconnect" or realign routes and schedules based on where and when people travel today. Reconnect is estimated to increase ridership by 5% with no additional increase in revenue service hours.

Step 2: Transit First Scenario

Once the bus network is reestablished to reflect the travel patterns of today, the next step in building a World Class Bus System is to: 1) invest in speed and reliability infrastructure, 2) create safe &

comfortable waiting environments, 3) improve the boarding and riding experience, and 4) establish facilities to optimize layovers. These capital improvements create a more competitive and attractive bus network while saving resources to be reinvested into more service.

- Speed and Reliability Improvements - As bus system speeds continue to decline, Metro must allocate an additional \$10 million cumulatively every year to provide the same amount of service. Not only does this reduce the opportunity to increase service, it degrades our competitiveness and attractiveness. Therefore, investing to improve the speed and reliability of the bus system is critical to the success of NextGen. Some improvements can be implemented within METRO's control, such as optimizing stop spacing, all door boarding, and headway-based service management. However, other improvements can only be implemented through collaboration with local jurisdictions, including transit priorities, bus bulb outs, and bus only lanes. Under the Transit First scenario, \$750 million in capital improvements are proposed to support speed and reliability improvements for the regional bus network. This investment is anticipated to save 25%-34% in system speed if fully implemented.
- Customer Wait Environment - Through the significant public outreach conducted in Phase 1, as well as other Metro efforts such as the How Women Travel Study, we learned that an uncomfortable and unsecured wait environment is a significant barrier for customers in using the bus network. This is particularly concerning for women who account for over half of our customers and often travel with young children. Metro completed the Transfer Design Guideline in March 2018. Under the Transit First scenario, we plan to begin implementing the recommendations from this policy document at our busiest wait and transfer locations. This investment is anticipated to cost \$150 million and address several of the safety and comfort issues identified in the NextGen outreach and How Women Travel Study.
- Boarding and Riding Experience - Metro has implemented All Door Boarding on several lines, including Orange Line, Silver Line, Line 720 (Wilshire), and Line 754 (Vermont). Experience on the Silver Line showed that dwell times were reduced by 15% on average, on time performance improved, cash payment declined with more TAP penetration, and significant customer and operator satisfaction. Other strategies to improve boarding and on board experience include level boarding at key stops and improved on board information. These improvements are estimated at \$100 million systemwide.
- Layover Optimization - Due to limited curb space, many routes are extended purely to access a layover location. These unnecessary route extensions cost several million dollars in operating cost per year with little to no benefit to the customer. By investing in off street layover terminals to optimize layover locations, we can reallocate wasted resources and reallocate it to more productive use. In addition, these locations would provide facilities for better regional mobility coordination, a better wait and rest environment for customers and operators, improve bus service reliability, and opportunities for new en route Zero Emissions Bus (ZEB) charging infrastructure.

With the investment in this \$1 billion capital program, we expect to achieve resource savings by generating more revenue service miles/trips within the same revenue service hours. These savings would be reinvested into Transit First service improvements, including:

- Ensure that all regular bus lines operate 7 days per week, including weekend service on eight lines;
- Ensure no wider than 30 min headways on any line between 6:00 am and 7:00 pm;
- Expand owl (overnight) service on an additional eight lines;
- Increase weekday midday and evening service levels;
- Increase weekday evening service levels.

Investing “one time” capital dollars into transit supportive infrastructure would increase the attractiveness and competitiveness of the bus network, while freeing resources to reinvest into service enhancements. Under the Transit First scenario, these benefits are expected to generate a 15-20% increase in ridership (10-15% over Reconnect) without additional increases in revenue service hours.

Step 3: Future Funding Scenario

Should future funding be secured through efforts such as de-congestion pricing, additional resources can be added to the Transit First network. However, without disincentives for driving, there will be diminishing returns on benefits since most customers would already have been served well within the Transit First Scenario. Therefore a 34% increase in revenue service hours would only be expected to yield a 10% increase in ridership over Transit First.

Summary of Benefits

The following is a summary of benefits from each scenario described above.

	Existing Conditions	Reconnect Scenario	Transit First Scenario	Future Funding Scenario
Revenue Service Hours	7 million	7 million	7 million	9.4 million
Revenue Service Miles	75 million	75 million	82 million	95 million
# High Freq Lines ¹ (weekdays)	16	28	29	46
# High Freq Lines ¹ (weekends)	2	14	14	19
Pop within walk access to High Freq Lines (weekdays)	900k	2.15m	2.17m	2.96m

Pop within walk access to High Freq Lines (weekends)	630k	1.14m	1.18m	1.49m
Ridership Change ²	0	+5%	+15-20%	+25-30%
% Riders who lose convenient access to transit ³	0	0.3%	0.3%	0.3%

Notes

¹ Every 10 min or better

² Compared to Existing Conditions

³ Beyond a 5 min walk (.25 mile) to a transit stop

Recommendation

Based on the benefits and costs identified above, staff recommends that the Board approve the Transit First scenario as the NextGen Service Plan to be released for public review and comment starting February 2020. This scenario includes:

- Service adjustments recommended through the Reconnect scenario (revenue service hour neutral);
- \$1 billion in transit supportive capital infrastructure to improve speed and reliability, customer wait environment, boarding and riding experience, and layover optimization.
- Reinvestment of resource savings from speed infrastructure and layover optimization into additional revenue service as outlined above

If fully implemented, the Transit First scenario is expected to achieve a 15-20% increase in ridership over current levels.

FINANCIAL IMPACT

Approving the Transit First scenario for public review and updates to the Transit Service Policy will not have an impact on the FY20 budget. However, future implementation of any components of the Transit First scenario will be evaluated for financial impact at that time based on cost and implementation schedule. Funding will be identified and programmed into the appropriate annual budget.

IMPLEMENTATION OF STRATEGIC PLAN GOALS

Recommendation supports strategic plan goal #1: Provide high quality mobility options that enable people to spend less time traveling. The study also encompasses two sub-goals: 1) Target infrastructure and service investments towards those with the greatest mobility needs; and 2) Invest in a world class bus system that is reliable, convenient, safe, and attractive to more users for more trips.

NEXT STEPS

Should the Board approve the recommendations above, staff will begin the public outreach process to review all route and schedule changes within Transit First with stakeholders and the public. Public workshops will be held between February and March 2020 followed by community and stakeholder meetings/briefings. The formal public hearing process to approve the service changes for implementation is scheduled to begin in June 2020 with Service Council consideration of approval in August 2020. If approved by the Service Councils, the final NextGen service plan will be presented to the Board for approval in September 2020. Assuming approval, the service plan will be implemented in two to three starting in December 2020, then June 2021 and possibly December 2021.

As a complementary effort, staff will continue to work with LADOT through the established traffic engineering working group to develop annual work programs to design, engineer, fund and construct the speed and reliability infrastructure. The customer experience and layover infrastructure will also be further defined and scoped. The individual elements of the Transit First capital program will be presented to the Board for approval of Life of Project (LOP) budget as they are defined and programmed through the annual budget development process for implementation.

ATTACHMENTS

Attachment A - NextGen Transit First service plan
Attachment B - Transit Service Policy

Prepared by: Conan Cheung, Sr. Executive Officer, Service Development, (213)418-3034

Reviewed by: James T. Gallagher, Chief Operations Officer, (213)418-3108

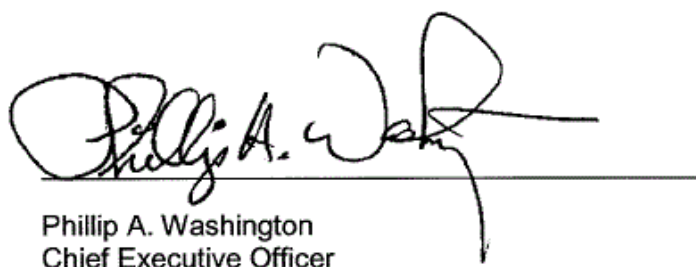

Phillip A. Washington
Chief Executive Officer

Transit First Service Plan

Core Network

Key spines in the network

Highest investment in customer and operations infrastructure

53% of today's bus riders use one of these top 25 corridors

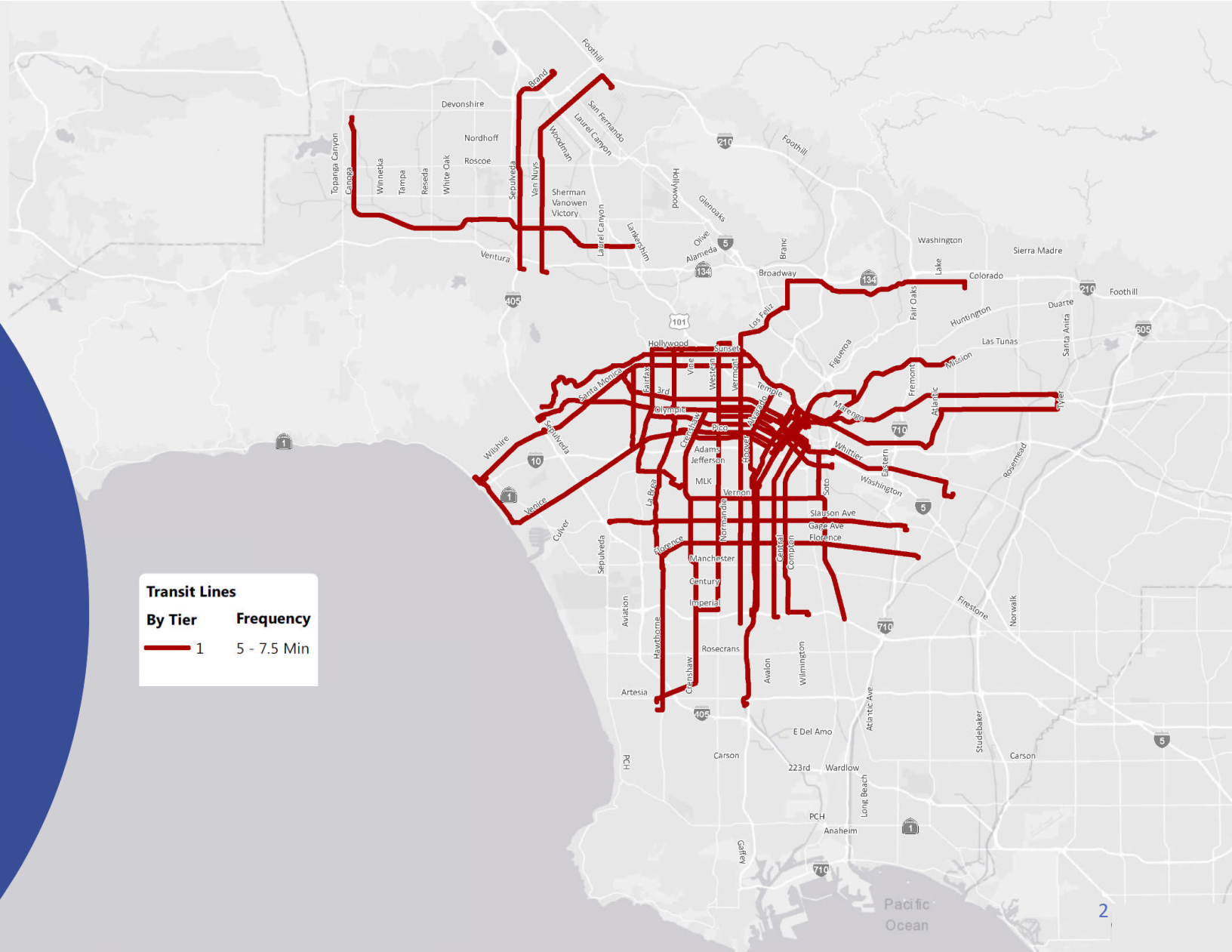

Convenience Network

81% of Metro's bus riders use a Tier 1 or 2 corridor

Completes the spontaneous-use network

Focuses on network continuity

High investment in customer and operations infrastructure

28% of today's bus riders use one of the 19 Tier 2 corridors

Transit Lines	
By Tier	Frequency
1	5 - 7.5 Min
2	10 Min

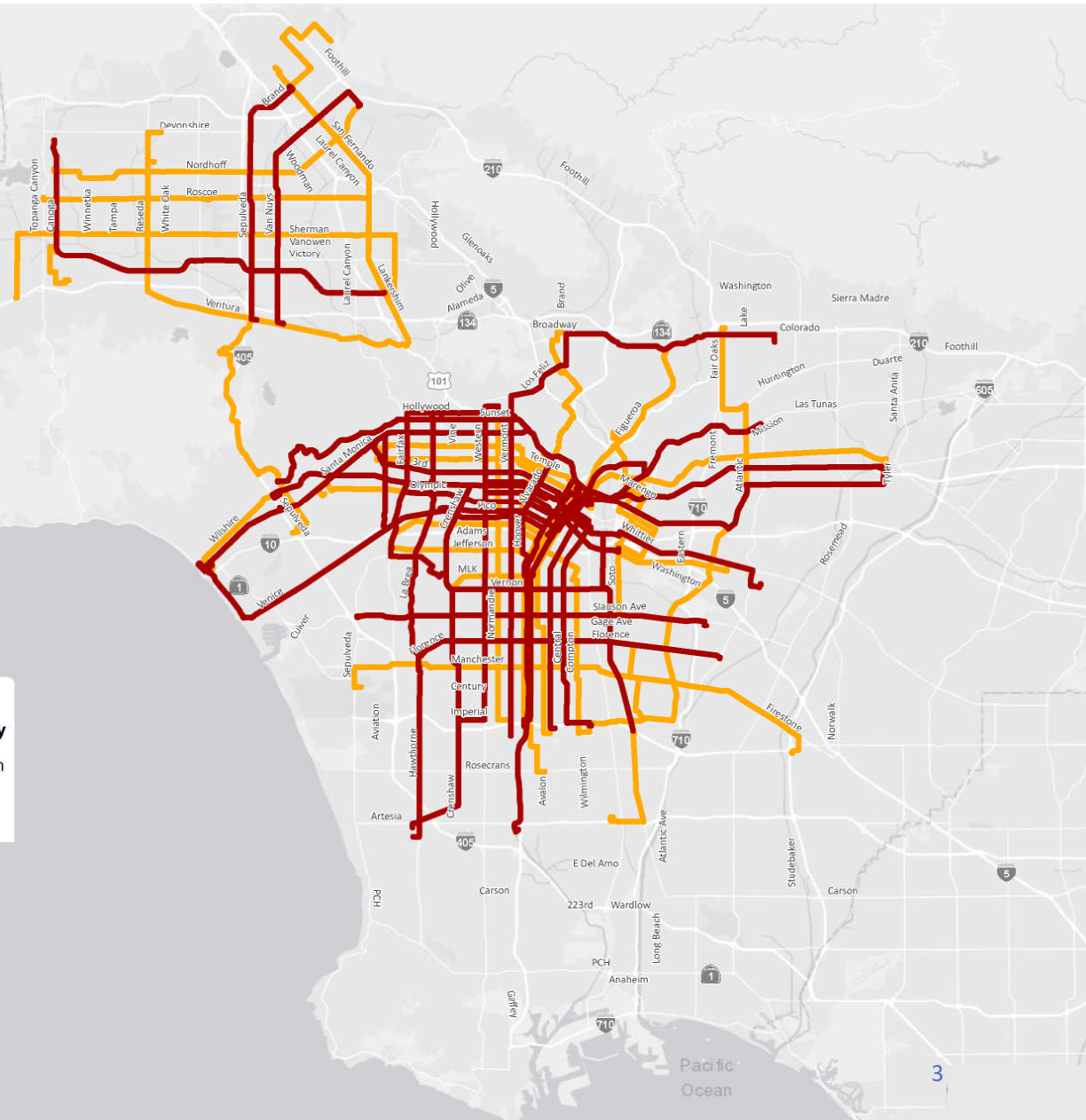

Connectivity Network

Completes the frequent network

Moderate investment in customer and operations infrastructure

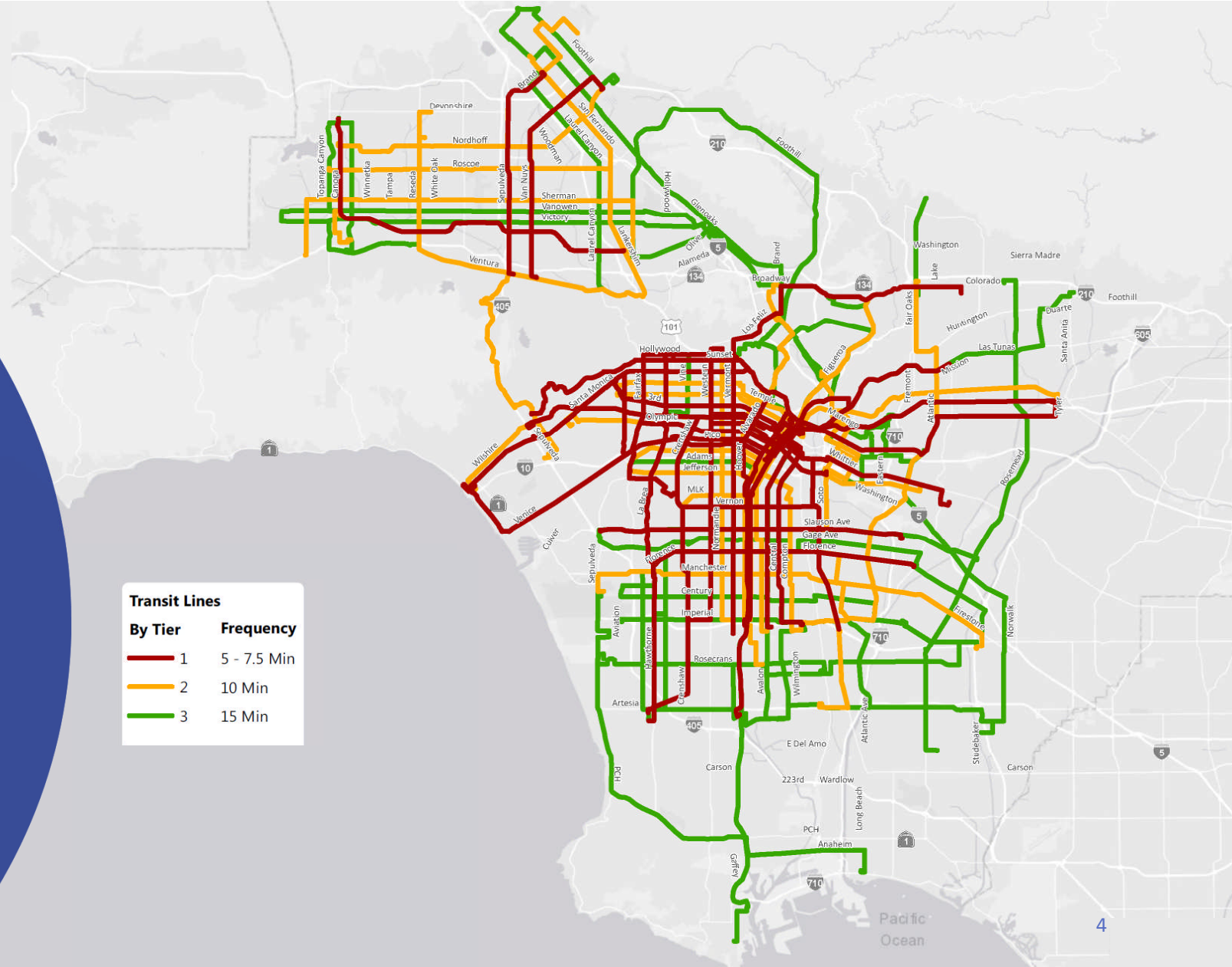

Community Network

Focuses on community travel in areas with lower demand; also includes Expresses

Minimal investment in customer and operations infrastructure

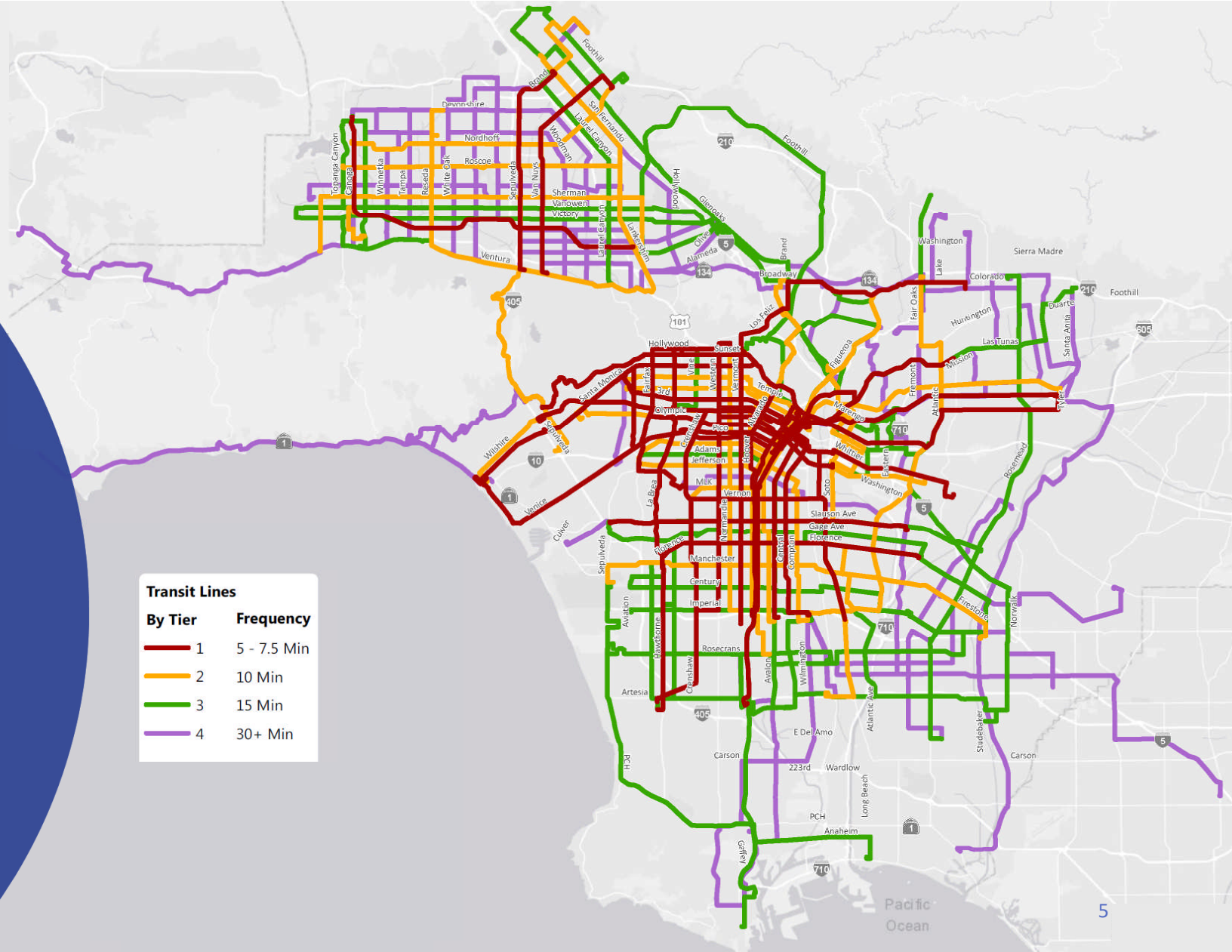

Full Network

The full network complements Muni lines, Metro Rail, & Metrolink services

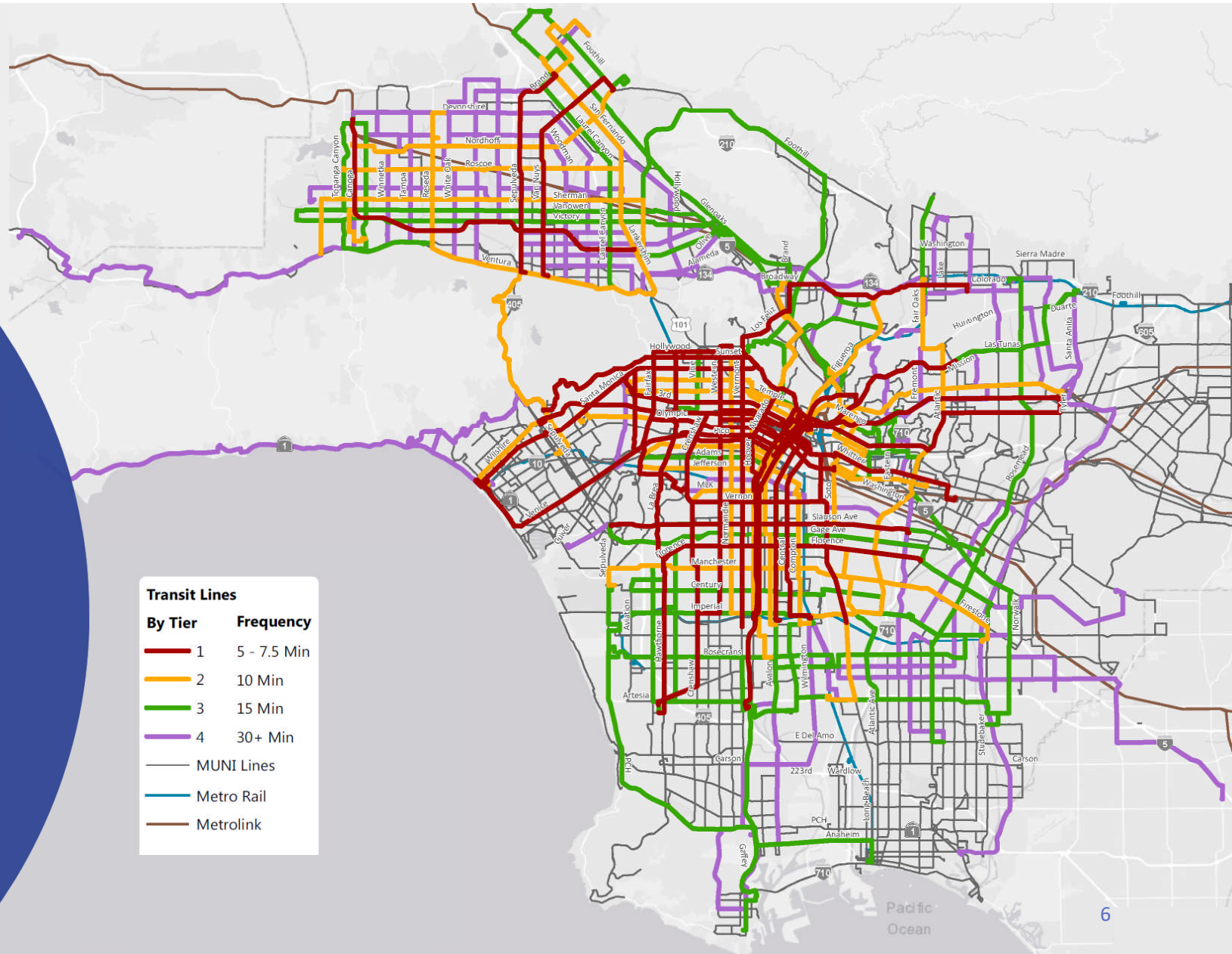

Attachment A
NextGen Transit First Service Change Proposals by Line

Line	Service Change Proposal	Existing Weekday Frequency						Proposed Weekday Frequency						Existing Saturday Frequency						Proposed Saturday Frequency						Existing Sunday Frequency						Proposed Sunday Frequency								
		AM Peak	Midday	PM Peak	Evening	Late Night	Owl	AM Peak	Midday	PM Peak	Evening	Late Night	Owl	AM Peak	Midday	PM Peak	Evening	Late Night	Owl	AM Peak	Midday	PM Peak	Evening	Late Night	Owl	AM Peak	Midday	PM Peak	Evening	Late Night	Owl	AM Peak	Midday	PM Peak	Evening	Late Night	Owl			
R2	New Line 2: Merge Lines 2 and 302 on Sunset Bl with Line 200 (Alvarado/Hoover): •New Line 2 would follow existing Lines 2 & 302 routes on Sunset Bl between UCLA and Hollywood, merging with existing Line 200 at Sunset & Alvarado to Exposition Park/USC via Alvarado, Hoover, Figueroa and MLK Jr New Line 2 would provide:	15	15	15	20	30	60	7.5	12	7.5	15	30	60	12	15	15	20	30	60	12	12	12	15	30	60	20	20	20	30	30	60	12	12	12	15	30	60			
R302	•New direct route between USC/Exposition Park and Hollywood	-	-	-	-	-	-	30	30	30	30	60	-	-	-	-	-	-	-	30	30	30	30	30	-	-	-	-	-	-	-	-	-	-	-	-	-			
R602	•High frequency service for all bus stops on Sunset Blvd and Alvarado St	-	-	-	-	-	-	-	-	-	-	-	-	-	-	-	-	-	-	-	-	-	-	-	-	-	-	-	-	-	-	30	30	30	30	30	-			
R200	•Underutilized bus stops would be consolidated to balance speed, reliability, and accessibility •Line 4 would remain serving Sunset Bl east of Alvarado St through downtown LA	8	12	7	20	40	-	-	-	-	-	-	-	12	12	10	20	40	-	-	-	-	-	-	-	20	13	10	25	40	-	-	-	-	-	-	-			
Sunset/ Alvarado	More frequent service would be provided all day on weekdays for Line 602.	6	15	7.5	20	30	60	7.5	12	7.5	15	30	60	12	15	15	20	30	60	12	12	12	15	30	60	20	20	20	30	30	60	12	12	12	15	30	60			
R4	New Line 4: Merge Lines 4 and 704 on Santa Monica Bl: •New Line 4 would follow the existing Line 4 & 704 routes between downtown Santa Monica and downtown LA via Santa Monica Bl and Sunset Bl	10	15	10	20	20	25	12	15	12	20	30	30	15	15	12	20	20	30	15	15	15	20	30	30	20	15	15	25	25	25	15	15	15	20	30	30			
RS4	•Bus stops between Westwood and downtown LA would be adjusted through consolidation of underutilized stops to balance speed, reliability, and accessibility, with bus stops for existing Line 704 retained between Westwood and downtown Santa Monica.	-	-	-	-	-	-	12	15	12	20	30	60	-	-	-	-	-	-	15	15	15	20	30	60	-	-	-	-	-	-	15	15	15	20	30	60			
R704	•More frequency for new Line 4 bus stops between Westwood and downtown LA.	10	15	10	20	20	-	-	-	-	-	-	-	20	20	20	25	25	-	-	-	-	-	-	-	30	20	20	25	25	-	-	-	-	-	-	-			
Santa Monica		5	7.5	5	10	10	25	6	7.5	6	10	15	20	9	9	7.5	12	12	30	7.5	7.5	7.5	10	15	20	12	9	9	13	13	25	7.5	7.5	7.5	10	15	20			
R10	Line 10 has no changes and would continue to operate in partnership with Line 48. Buses continuing to change between these two lines at Temple/Figueroa in downtown LA. Line 10 would have more frequency during midday and evening hours on weekdays.	8	20	10	30	60	60	10	15	10	15	30	-	20	20	20	18	60	60	20	20	20	20	30	-	30	20	20	40	60	60	20	20	20	20	30	-			
R14	Line 14 would continue between downtown Los Angeles to Beverly/San Vicente via Beverly Bl and then travel north on San Vicente to Santa Monica Blvd then connect to Line 4: •Line 14 would have more frequency during midday and evening hours on weekdays. •Existing Line 14 segment west of Beverly/San Vicente to Pico Bl via Beverly Dr would be discontinued due to underutilized service. Nearest alternative bus service would be on Robertson Bl (Line 17), Santa Monica Bl (Line 4), Wilshire Bl (Line 20), Olympic Bl (Line 28), and Pico Bl (Big Blue Bus Line 7). •Line 14 would continue to operate in partnership with Line 37, with buses still changing to Line 37 at 1st/Beadry in downtown LA	6	15	8	15	60	60	10	15	10	15	30	-	25	20	17	30	60	60	20	20	20	20	30	-	25	20	20	25	60	60	20	20	20	20	30	-			
R16	New Line 16: Merge Lines 16, 17, and 316.	10	10	20	15	30	-	6	7.5	6	10	15	60	10	8	6	10	20	-	7.5	7.5	7.5	10	15	30	12	8	8	20	20	-	7.5	7.5	7.5	10	15	30			
R17	New Line 16 will operate between downtown LA and 3rd St/San Vicente via 3rd St, then north on San Vicente to Santa Monica Bl to connect with Line 4: •Line 16 and 316 would no longer continue west of 3rd St/San Vicente at Beverly Hills on Burton due to underutilized service	25	60	30	60	-	-	-	-	-	-	-	-	-	-	-	-	-	-	-	-	-	-	-	-	-	-	-	-	-	-	-	-	-	-	-	-			
R617	•Lines 4 (Santa Monica Bl) or Line 28 (Olympic Bl) would be available service at Century City •New Line 16 will have more frequency during midday and evening hours on weekdays	-	-	-	-	-	-	30	30	30	30	-	-	-	-	-	-	-	-	45	45	45	45	-	-	-	-	-	-	-	-	45	45	45	45	-	-			
R316	New Line 617 would operate between E Line (Expo) Culver City Station to Cedars-Sinai Medical Center/Beverly Center via Robertson Bl, to operate more reliably: •New Line 617 will have more frequency during midday and evening hours on weekdays, as well as new Saturday and Sunday service	8	-	8	-	-	-	-	-	-	-	-	-	-	-	-	-	-	-	-	-	-	-	-	-	-	-	-	-	-	-	-	-	-	-	-	-			
3rd		4	9	5	12	30	-	6	7.5	6	10	15	60	10	8	6	10	20	-	7.5	7.5	7.5	10	15	30	12	8	8	20	20	-	7.5	7.5	7.5	10	15	30			
R18	New Line 18: Merge Line 18 and Line 720. New Line 18 would operate between Metrolink Montebello-Commerce Station and downtown LA: •More frequency for all new Line 18 bus stops between East LA and downtown LA •New Line 18 service would continue between downtown LA and Wilshire/Western via 6th St •Underutilized bus stops would be consolidated to balance speed, reliability, and accessibility.	5	10	8	22	30	60	6	7.5	6	10	15	30	7.5	12	12	25	30	60	7.5	7.5	7.5	10	15	30	15	15	12	25	30	60	7.5	7.5	7.5	10	15	30			
RS20		10	12	10	20	30	30	10	10	10	15	-	-	20	15	15	25	30	30	12	12	12	15	-	-	25	20	20	20	30	30	12	12	12	15	-	-			
RL20	New High Frequency Line 20: Merge Line 20 and Line 720 between downtown Santa Monica and downtown LA via Wilshire Bl., following the existing Line 20/720 route: •More frequency for all new Line 20 bus stops between Westwood and downtown LA •Underutilized Line 20 bus stops between Westwood and downtown LA would be consolidated to balance speed, reliability, and accessibility, •New Line 20 would serve existing Line 720 stops west of Sepulveda Bl to Santa Monica •New Line R20 would operate peak periods weekdays serving existing Line 720 stops between downtown LA and Santa Monica	10	10	4	10	15	-	10	-	10	-	-	-	12	10	8	10	15	-	-	-	-	-	-	-	20	10	10	15	15	-	-	-	-	-	-	-			
Wilshire		5	5	5	6	10	30	5	5	5	7.5	15	30	-	-	-	-	-	-	6	6	6	7.5	15	30	-	-	-	-	-	-	6	6	6	7.5	15	30			
R28	New High Frequency Line 28: Merge Line 28 & Line 728. New Line 28 would operate between Century City, downtown LA and Eagle Rock via Olympic Bl between Century City and downtown LA New Line 684 will link Gold Line Lincoln/Cypress Station and Eagle Rock: •More frequency during weekdays and weekends at all bus stops between Century City and downtown LA •Underutilized stops between Century City and downtown LA on Olympic Bl would be consolidated to balance speed, reliability, and accessibility, •New Line 684 would link Gold Line Lincoln/Cypress Station and Eagle Rock via existing Line 28. •Line 45 would serve the section of Line 28 on Broadway between downtown LA and Avenue 26	12	30	15	30	30	60	15	20	15	15	30	-	15	12	12	20	30	60	15	15	15	15	30	-	18	15	15	25	30	60	15	15	15	15	30	-			
RS28		-	-	-	-	-	-	15	20	15	-	-	-	-	-	-	-	-	-	-	-	-	-	-	-	-	-	-	-	-	-	-	-	-	-	-	-			
R684		-	-	-	-	-	-	30	30	30	30	60	-	-	-	-	-	-	60	30	30	60	60	-	-	-	-	-	-	60	30	30	60	60	-	-	-	-	-	-
R728		10	20	12	30	-	-	-	-	-	-	-	-	-	-	-	-	-	-	-	-	-	-	-	-	-	-	-	-	-	-	-	-	-	-	-	-			
Olympic		6	12	7	15	30	60	7.5	10	7.5	15	30	-	15	12	12	20	30	60	15	15	15	15	30	-	18	15	15	25	30	60	15	15	15	15	30	-			
R30	New Frequent Line 30: Merge Lines 30 & 330 between West Hollywood and Gold Line Indiana Station via San Vicente Bl, Pico Bl, and 1st St, via existing Lines 30/330 between Pico Rimpau Transit Center and Gold Line Little Tokyo/Arts District Station: •Existing Line 30/330 service on San Vicente Bl would be discontinued, with alternative bus service available on Olympic Bl (Line 28), Wilshire Bl (Lines 20, 320), 3rd St (Line 16), Beverly Bl (Line 14), Santa Monica Bl (Line 4) •Existing Line 30 service between Little Tokyo and Indiana Gold Line stations would be eliminated, with alternative service available on the Gold Line •Underutilized bus stops will be consolidated on Pico Bl to balance speed, reliability, and accessibility.	12	12	12	10	30	60	10	10	10	15	30	-	8	12	10	20	30	60	15	15	15	15	30	-	15	12	10	25	30	60	15	15	15	15	30	-			
R330		12	-	20	-	-	-	-	-	-	-	-	-	-	-	-	-	-	-	-	-	-	-	-	-	-	-	-	-	-	-	-	-	-	-	-	-			
Pico		6	12	7	10	30	60	10	10	10	15	30	-	8	12	10	20	30	60	15	15	15	15	30	-	15	12	10	25	30	60	15	15	15	15	30	-			
R33	New Line 33: Merge Lines 33 & 733 on Venice Bl, following existing Line 33/733 alignment between downtown Santa Monica and downtown LA via Venice Bl: •New Line 33 route would be modified to serve Pico Station in downtown LA •Increased service frequency for all new Line 33 bus stops between Santa Monica and downtown LA •Underutilized stops between Santa Monica and downtown LA would be consolidated to balance speed, reliability, and accessibility	12	20	12	20	30	30	7.5	10	7.5	10	30	60	20	20	13	15	25	30	10	10	10	10	30	60	30	20	20	20	25	30	10	10	10	10	30	60			
R733		15	20	15	20	30	-	-	-	-	-	-	-	20	20	20	30	30	-	-	-	-	-	-	-	20	20	20	20	30	-	-	-	-	-	-	-			
Venice		7	10	7	10	15	30	7.5	10	7.5	10	30	30	10	10	7.5	10	15	30	10	10	10	10	30	60	12	10	10	10	15	30	10	10	10	10	30	60			
R35	Line 35 has no route changes: •More frequency during midday and late-night hours on weekdays	10	15	12	20	60	-	12	12	12	15	30	-	15	15	15	40	60	-	20	15	15	20	30	-	40	20	20	40	60	-	20	15	15	20	30	-			
R40	New High-Frequency Line 40: Merge Lines 40 & 740. This new line 40 would operate between LA Union Station and downtown Inglewood Station via Broadway, ML King Jr Bl, Crenshaw Bl, Florence Av: •More frequency for all bus stops on Broadway, ML King Jr Bl, Crenshaw Bl, and Florence Av •Underutilized bus stops will be consolidated on Broadway, ML King Jr Bl, Crenshaw Bl, and Florence Av to balance speed, reliability, and accessibility •Line 40 Overnight Owl service between LAX and downtown LA would be discontinued, with alternative Owl service available on Lines 45 and 111 •New Line 212 would serve La Brea Av, Hawthorne Bl south of downtown Inglewood Station ending at South Bay Galleria	12	20	15	15	25	60	10	10	10	15	30	-	20	20	20	24	60	60	15	15	15	15	30	-	20	20	20	20	60	60	15	15	15	15	30	-			
R740		18	30	18	20	-	-	-	-	-	-	-	-	20	30	20	20	-	-	-	-	-	-	-	-	-	-	-	-	-	-	-	-	-	-	-	-			
Hawthorne		7.5	12	8	8	25	60	10	10	10	15	30	-	10	12	10	12	60	60	15	15	15	15	30	-	20	20	20	20	60	60	15	15	15	15	30	-			

Line	Service Change Proposal	Existing Weekday Frequency						Proposed Weekday Frequency						Existing Saturday Frequency						Proposed Saturday Frequency						Existing Sunday Frequency						Proposed Sunday Frequency					
		AM Peak	Midday	PM Peak	Evening	Late Night	Owl	AM Peak	Midday	PM Peak	Evening	Late Night	Owl	AM Peak	Midday	PM Peak	Evening	Late Night	Owl	AM Peak	Midday	PM Peak	Evening	Late Night	Owl	AM Peak	Midday	PM Peak	Evening	Late Night	Owl	AM Peak	Midday	PM Peak	Evening	Late Night	Owl
R45	New High Frequency Line 45: Merge Lines 45 & 745 on Broadway St: •New Line 45 would follow existing route between Harbor Freeway Station, downtown LA, and Lincoln Heights via Broadway St •More frequency for all new Line 45 bus stops •Underutilized bus stops on Broadway St would be consolidated to balance speed, reliability, and accessibility •Line 127 will replace the segment of Line 45 south of Harbor Freeway Station on 117th St, Broadway St, El Segundo Bl, and Main St to San Pedro & Rosecrans (see Line 127 information sheet)	5	15	10	25	60	60	5	7.5	5	10	30	60	9	8	15	30	60	60	7.5	7.5	7.5	15	30	60	20	12	15	30	60	60	7.5	7.5	7.5	15	30	60
R745		8	15	10	30	-	-	-	-	-	-	-	-	12	18	20	20	-	-	-	-	-	-	-	-	30	30	30	30	-	-	-	-	-	-	-	-
Broadway		3	7.5	5	15	60	60	5	7.5	5	10	30	60	6	6	8	12	60	60	7.5	7.5	7.5	15	30	60	12	9	10	15	60	60	7.5	7.5	7.5	15	30	60
R51	New Line 51: Merge Lines 51, 52, 352 on San Pedro St and Avalon Bl. New Line would follow existing routes between downtown LA, San Pedro St, and Avalon Bl, with a new southern terminus at Cal State Dominguez Hills •Lines 51/52/351 would not operate between downtown LA and Wilshire/Vermont, with alternative service available on Wilshire Bl (Line 20) and 8th St (Line 66) •Line 127 would replace Lines 51/351 on Compton Bl and Line 52 on Victoria St (see Line 127 information sheet) •More frequency would be provided for all bus stops on San Pedro St and Avalon Bl, with highest frequency provided north of the Green Line Avalon Station •Underutilized bus stops would be consolidated to balance speed, reliability, and accessibility.	10	24	20	15	60	60	15	15	15	30	30	60	10	7.5	10	20	60	-	20	20	20	20	30	60	30	10	10	60	60	-	20	20	20	20	30	60
R551		-	-	-	-	-	-	15	15	15	-	-	-	-	-	-	-	-	-	20	20	20	-	-	-	-	-	-	-	-	-	20	20	20	-	-	-
R52		20	24	20	60	-	-	-	-	-	-	-	-	30	30	30	40	-	-	-	-	-	-	-	-	30	20	30	60	-	-	10	10	10	20	30	60
R351		20	-	20	-	-	-	-	-	-	-	-	-	-	-	-	-	-	-	-	-	-	-	-	-	-	-	-	-	-	-	-	-	-	-	-	-
Avalon	5	12	6	12	60	60	7.5	7.5	7.5	30	30	60	7.5	6	7.5	12	60	-	10	10	10	20	30	60	15	6	7.5	30	60	-	10	10	10	20	30	60	
R53	Line 53 between downtown LA and Cal State Dominguez Hills via Central Av would be changed as follows: •More frequency during the midday and evening hours on weekdays •Reroute Line 53 to serve the A Line (Blue) Line Willowbrook/Rosa Parks Station (instead of Green Line Avalon Station) to connect with both the A (Blue) Line and Green Line •Selected Line 53 trips will continue south of the A Line (Blue) Willowbrook/Rosa Parks Station to Cal State Dominguez Hills •Reroute Line 53 in downtown LA from Beaudry Av to Olive St to serve more destinations and a new connection to Line 4 (Line 55 will replace Line 53 on Beaudry Ave)	8	15	8	30	60	-	20	20	20	20	30	-	12	15	15	20	60	60	20	20	20	20	30	-	30	20	20	30	60	60	20	20	20	20	30	-
R553		-	-	-	-	-	-	20	20	20	-	-	-	-	-	-	-	-	-	-	-	-	-	-	-	-	-	-	-	-	-	-	-	-	-	-	-
Central		8	15	8	30	60	-	10	10	10	20	30	-	12	15	15	20	60	60	20	20	20	20	30	-	30	20	20	30	60	60	20	20	20	20	30	-
R55	New Line 55: Merge Lines 55 & 355 between downtown LA and Willowbrook/Rosa Parks Station via Adams Bl and Compton Av: •New Line 55 would follow existing Line 55/355 route with all trips ending at Willowbrook/Rosa Parks Station •More frequency for all bus stops on Adams Bl and Compton Av •Underutilized stops would be consolidated to balance speed, reliability, and accessibility •Line 55 in downtown LA would be rerouted on Beaudry Av, maintaining Metro rail connections •Eliminate Line 55 segment via Firestone Station to travel direct on Compton Av •Underutilized late-night Owl service would be discontinued. Nearest alternative late night Owl service would be Avalon Bl (Line 51)	15	20	15	60	60	60	12	12	12	15	30	60	12	15	15	30	60	60	20	20	20	20	30	60	30	23	23	60	60	60	20	20	20	20	30	60
R355		20	-	20	-	-	-	-	-	-	-	-	-	-	-	-	-	-	-	-	-	-	-	-	-	-	-	-	-	-	-	-	-	-	-	-	-
Adams/Compton		8	20	8	60	60	60	12	12	12	15	30	60	12	15	15	30	60	60	20	20	20	20	30	60	30	23	23	60	60	60	20	20	20	20	30	60
R60	New High Frequency Line 60: Merge Lines 60 & 760 on Long Beach Blvd between downtown LA, Green Line Long Beach Blvd and A Line (Blue) Artesia Stations: •New Line 60 would follow the existing Line 60 route between downtown LA and A Line (Blue) Artesia Station •High frequency service would be provided for all new Line 60 bus stops •More high frequency would be available north of Green Line Long Beach Bl Station •Underutilized bus stops on Santa Fe Av and Long Beach Bl would be consolidated to balance speed, reliability and accessibility •New Line 60 would include a reroute in downtown LA from Figueroa St to Olive St	7.5/15	15	7.5/15	20	23	60	10	10	10	15	30	60	15	10	15	30	34	60	10	10	10	15	30	60	20	12	12	30	34	60	10	10	10	15	30	60
R560		-	-	-	-	-	-	10	-	10	-	-	-	-	-	-	-	-	-	-	-	-	-	-	-	-	-	-	-	-	-	-	-	-	-	-	-
R760		12	20	15	30	-	-	-	-	-	-	-	-	20	30	25	60	-	-	-	-	-	-	-	-	-	-	-	-	-	-	-	-	-	-	-	-
Long Beach Blvd	5/7.5	8	5/7.5	12	23	60	5	10	5	15	30	30	9	7.5	10	20	34	60	10	10	10	15	30	60	20	12	12	30	34	60	10	10	10	15	30	60	
R62	New Line 262: New Line 262 will operate between East LA College, Gold Line Atlantic Station, and Los Cerritos Center, via Atlantic Ave, Telegraph Rd, Pioneer Bl: •Line 62 will be discontinued between downtown Los Angeles and Hawaiian Gardens via Telegraph Rd, Norwalk Bl, and Pioneer Bl. This would remove service duplication with Line 66 west of Atlantic Bl/Telegraph Rd to downtown LA. •New connection to East LA College will be created •Discontinue existing Line 62 on Imperial Hwy/Bloomfield Av at Norwalk, reducing overlap of Norwalk Transit service, providing better service on Pioneer Bl. •Discontinue existing Line 62 south of Los Cerritos Center due to underutilized service, with nearest alternative lines available on Long Beach Transit Lines 173 and Cerritos on Wheels	16	33	25	60	60	-	-	-	-	-	-	-	60	35	30	60	60	-	-	-	-	-	-	-	60	60	60	60	60	-	-	-	-	-	-	-
R262		-	-	-	-	-	-	20	20	20	30	60	-	-	-	-	-	-	-	60	30	30	60	60	-	-	-	-	-	-	-	60	30	30	60	60	-
R66	Line 66 between Red Line Wilshire/Western Station and Metrolink Montebello Station via Western Av, 8th St, and Olympic Bl will change as follows: •Replace the deviation along 8th St in East LA with Line 66 traveling direct on Olympic Bl, replacing Line 62 and providing faster more direct service. •Line 605 would still be available on 8th St. •Discontinue service between Olympic & Gerhart and Metrolink Montebello Station due to underutilized service and to reduce overlap of lines, with Line 66 ending at Commerce Center. •Line 18 would provide alternative service to Metrolink Montebello Station	6	20	15	20	60	-	10	10	10	15	30	-	8.5	15	15	30	60	-	15	15	15	15	30	-	22	20	20	30	60	-	15	15	15	15	30	-
R68	New Frequent Line 70 replaces Line 68 between downtown LA and East LA College via Cesar E Chavez Av (see Line 70 information sheet): •Discontinue existing segment of Line 68 east of Atlantic Bl due to underutilized service. •Access to The Shops at Montebello would be available through a connection between Metro Line 18 and Montebello Bus Line 70 at Whittier Bl and Garfield Av	15	20	15	30	45	-	-	-	-	-	-	-	20	20	20	30	40	-	-	-	-	-	-	-	30	20	15	25	45	-	-	-	-	-	-	-
R770		12	15	12	30	-	-	-	-	-	-	-	-	20	22	22	-	-	-	-	-	-	-	-	-	-	-	-	-	-	-	-	-	-	-	-	-
R70	New Higher Frequency Line 70: Merge Lines 70 and 770 New Line 70 would operate between downtown LA and El Monte Station via Garvey Av. The route will follow the existing Line 70 route via Garvey Av, Atlantic Bl, and Cesar Chavez Av: •Alternative New Line 106 would Replace Line 70 service on Ramona Bl and Marengo St. •Underutilized bus stops on Garvey Ave, Atlantic Blvd, and Cesar Chavez Ave would be consolidated to balance speed, reliability and accessibility. •New Overnight Owl service on Cesar Chavez Ave	12	15	12	25	60	60	7.5	7.5	7.5	10	30	60	15	20	15	30	60	60	10	10	10	15	30	60	15	15	15	35	60	60	10	10	10	15	30	60
R71		15	35	35	60	-	-	-	-	-	-	-	-	60	60	60	60	-	-	-	-	-	-	-	-	60	60	60	60	-	-	-	-	-	-	-	-
Garvey/Cesar Chavez		6	7.5	6	15	60	60	7.5	7.5	7.5	10	30	60	10	10	10	30	60	60	10	10	10	15	30	60	15	15	15	30	60	60	10	10	10	15	30	60
R76	Line 76 between downtown LA and El Monte Bus Station via Main St and Valley Blvd would continue to follow the majority of the existing alignment operating more frequent midday and evening service during the weekdays: •Line 76 would no longer travel to the Metrolink El Monte Station due to underutilized service and will instead operate on Santa Anita Av. The Metrolink El Monte Station would be served by City of El Monte's shuttle & trolley services •Line 76 in downtown LA would continue operating on Alameda St. to 1st St. then existing route to 7th St./Maple St.	12	15	12	45	60	60	12	12	12	15	60	60	20	20	15	35	60	60	20	20	20	30	60	60	30	20	20	45	60	60	20	20	20	30	60	60
R78	New Frequent Line 78: Merge Lines 78, 79, and 378 between downtown LA and Arcadia. Route would follow Mission Rd, Huntington Dr then continue along Main St/Las Tunas Dr, Baldwin, back to Huntington Dr with a new connection to Gold Line Arcadia Station •Discontinue Line 78 service on Live Oak Av east of Baldwin Av •Discontinue Line 79 service on Huntington Dr east of Maycrest Av to Baldwin Av due to underutilized service. •Foothill Transit Line 187 would provide alternative service on Huntington Dr at Rosemead Bl to the Gold Line Arcadia Station •Underutilized bus stops would be consolidated to balance speed, reliability, accessibility.	20	15	15	45	60	-	20	20	20	20	30	-	20	15	12	45	60	-	20	20	20	30	60	-	40	32	18	60	60	-	20	20	20	30	60	-
R578		-	-	-	-	-	-	20	20	20	-	-	-	-	-	-	-	-	-	-	-	-	-	-	-	-	-	-	-	-	-	-	-	-	-	-	-
R378		20	-	20	-	-	-	-	-	-	-	-	-	-	-	-	-	-	-	-	-	-	-	-	-	-	-	-	-	-	-	-	-	-	-	-	-
R79		22	40	30	60	60	-	-	-	-	-	-	-	45	45	40	40	60	-	-	-	-	-	-	-	45	32	40	40	60	-	-	-	-	-	-	-
Mission/Las Tunas	7	10	7	24	30	-	10	10	10	20	30	-	12	12	9	15	30	-	20	20	20	30	60	-	22	16	13	24	30	-	20	20	20	30	60	-	

Line	Service Change Proposal	Existing Weekday Frequency						Proposed Weekday Frequency						Existing Saturday Frequency						Proposed Saturday Frequency						Existing Sunday Frequency						Proposed Sunday Frequency					
		AM Peak	Midday	PM Peak	Evening	Late Night	Owl	AM Peak	Midday	PM Peak	Evening	Late Night	Owl	AM Peak	Midday	PM Peak	Evening	Late Night	Owl	AM Peak	Midday	PM Peak	Evening	Late Night	Owl	AM Peak	Midday	PM Peak	Evening	Late Night	Owl	AM Peak	Midday	PM Peak	Evening	Late Night	Owl
		R81	Line 81 route would remain same south of Figueroa St and Yosemite Dr between Harbor Freeway Silver/Green Line Station, downtown LA, and Eagle Rock. Line 81 will replace Line 181 and will be rerouted via Yosemite St to provide service to Colorado Bl/Eagle Rock.	8	15	10	35	60	-	20	20	20	30	60	60	20	20	15	30	60	-	20	20	20	20	30	60	25	25	22	30	60	-	20	20	20	20
RS81	•More frequency during midday hours on weekdays	-	-	-	-	-	-	20	20	20	30	60	60	-	-	-	-	-	-	-	-	-	-	-	-	-	-	-	-	-	-	-	-	-	-	-	-
Figueroa	•Selected trips would continue to end at Figueroa/Colorado •New Overnight Owl Service (in place of Line 83) to Figueroa/Colorado, connecting with Line 180 Overnight Owl service	8	15	10	35	60	-	10	10	10	15	30	30	20	20	15	30	60	-	20	20	20	20	30	60	25	25	22	30	60	-	20	20	20	20	30	60
R83	Line 83 would be replaced with new Line 182 between downtown LA and Eagle Rock via York Blvd and Pasadena Ave and would be extended to East Hollywood (Red Line Vermont/Sunset Station) via York St, Eagle Rock Bl, Fletcher Dr, Rowena Av, and Franklin St: •This new segment provides a more direct east-west connection between Northeast LA and Hollywood while maintaining service to John Marshall High School, and replacing Line 175	23	40	25	40	-	-	-	-	-	-	-	-	35	40	40	40	-	-	-	-	-	-	-	-	34	40	35	40	-	-	-	-	-	-	-	-
R182	•New Line 182 would begin from Lincoln/Cypress Gold Line Station (rather than Downtown LA) via Pasadena Ave and Figueroa St rather than Marmion Wy and Monte Vista St •Frequent alternative service to/from downtown LA is available on Figueroa St (Line 81) and the Gold Line •New Line 81 Overnight Owl Service will replace Line 83 Overnight Owl Service.	-	-	-	-	-	-	30	30	30	30	60	-	-	-	-	-	-	-	60	30	30	30	60	-	-	-	-	-	-	-	60	30	30	30	60	-
R290	New Line 290: Merge Lines 90 & 91 on Foothill Blvd: •New Line 290 would connect with Gold Line Lincoln/Cypress Station for frequent rail connections to downtown LA then extend via Daly St to LA County USC Medical Center	-	-	-	-	-	-	20	20	20	30	60	-	-	-	-	-	-	-	30	30	30	60	60	-	-	-	-	-	-	-	30	30	30	60	60	-
R90	•Line 94 will provide service on Hill St	25	40	30	60	60	-	-	-	-	-	-	-	60	60	60	60	60	-	-	-	-	-	-	-	60	60	60	60	60	-	-	-	-	-	-	-
R91	•On the north end, new Line 290 would be routed on Vineland Av from Sunland to North Hollywood Station, for better connections to bus and rail service	28	30	30	60	60	-	-	-	-	-	-	-	60	60	60	60	60	-	-	-	-	-	-	-	60	60	60	60	60	-	-	-	-	-	-	-
Foothill Blvd	•Line 90 north of Sunland Bl would be discontinued. And new Line 690 would operate on a segment of Foothill Bl between Lake View Terrace and Sylmar	13	18	15	30	30	-	20	20	20	30	60	-	30	30	30	30	30	-	30	30	30	60	60	-	30	30	30	30	30	-	30	30	30	60	60	-
R92	Line 92 will be extended south to Venice & Broadway in downtown LA and operate more frequency.	25	25	25	35	60	60	20	20	20	30	60	-	30	30	30	60	60	60	30	30	30	30	60	60	40	40	40	60	60	60	30	30	30	30	60	60
R292		35	45	35	40	60	-	-	-	-	-	-	-	45	45	45	45	-	-	-	-	-	-	-	-	40	40	40	40	60	-	-	-	-	-	-	-
Glenoaks		25	25	25	35	60	60	20	20	20	30	60	-	30	30	30	60	60	60	30	30	30	30	60	60	40	40	40	60	60	60	30	30	30	30	60	60
R94	New Lines 94 and 794: Merge Lines 94 and 794 on San Fernando Rd: •New Line 94 would operate via the existing Line 94 route between downtown LA and downtown Burbank, then extend west on Magnolia Blvd to end at the Red Line North Hollywood Station. This new route would provide more service between Burbank and North Hollywood.	20	30	25	35	60	-	15	15	15	30	60	60	20	22	20	30	60	-	30	30	30	30	60	60	30	20	20	30	60	-	30	30	30	30	60	60
R294	•A new Line 294 would operate along San Fernando Rd between Sylmar and downtown Burbank. (See New Line 294 information sheet.)	-	-	-	-	-	-	30	30	30	30	60	-	-	-	-	-	-	-	30	30	30	30	60	-	-	-	-	-	-	-	30	30	30	30	60	-
R794	•Underutilized bus stops on new Line 294 would be consolidated between North Hollywood and downtown LA to balance speed, reliability, and accessibility	20	30	20	60	-	-	-	-	-	-	-	-	-	-	-	-	-	-	-	-	-	-	-	-	-	-	-	-	-	-	-	-	-	-	-	-
San Fernando	•Frequent service would be available at all new Line 94 bus stops	10	15	12	20	60	-	15	15	15	30	60	60	-	-	-	-	-	-	30	30	30	30	60	60	-	-	-	-	-	-	30	30	30	30	60	60
R96	Line 96 is will be replaced by the following service: •Lines 92 and 94 would provide service between Burbank, Glendale, and downtown LA •Line 501 between North Hollywood, Burbank, Glendale, and Pasadena would include a new stop at the LA Zoo, with connections to downtown LA available on Brand Bl at Glendale with Line 92. San Fernando Valley residents would have more frequent service to LA Zoo and Griffith Park with direct connections to the Red Line and Orange Line. •Lines 81 and 94 would operate on Hill St to serve Chinatown •Line 92 would serve Echo Park at Glendale Bl Refer to Line 81, Line 92, Line 94, and Line 501 information pages.	28	40	30	55	-	-	-	-	-	-	-	-	50	55	52	55	-	-	-	-	-	-	-	-	60	60	60	60	-	-	-	-	-	-	-	-
R102	New Line 102 would operate between Slauson/Atlantic and Crenshaw/43rd: •Service would be discontinued on Stocker St due to underutilized service, with alternative service on Crenshaw Bl (Line 210), La Brea Av (Line 212) and on La Tijera Bl (with alternative service Slauson Av (Line 108), Centinela Av (Line 110) or Manchester Ave (Line 115)) •Future Crenshaw/LAX light rail service would also connect to LAX area •Reroute Line 102 east of Central Av/41st St to Vernon and Maywood (Slauson/Atlantic) via Central Ave, Vernon Av, Pacific Av, Leonis Bl, District Bl, Atlantic Bl, replacing Line 611 •Line 102 to South Gate via Hooper Av, Gage Av, Central Av, Florence Av, Seville Av would be discontinued due to underutilized service, with alternative service available on Lines 53, 111, 251	34	60	35	55	60	-	30	30	30	30	60	-	30	60	30	60	60	-	30	30	30	30	60	-	30	60	30	60	60	-	30	30	30	30	60	-
R105	New High Frequency Line 105: Merge Lines 105 & 705 on Vernon Av, Martin Luther King, Jr. Bl, and La Cienega Bl between Vernon and West Hollywood: •All New Line 105 trips would continue to serve Santa Rosalia Dr between Hillcrest Dr and Marilton Av	12	18	15	30	60	60	10	10	10	15	30	60	15	15	13	25	60	60	15	15	15	30	30	60	25	16	16	35	60	60	15	15	15	30	30	60
R705	•Discontinue Line 705 segment on Martin Luther King Jr. Bl between Hillcrest Dr and Marilton Av	12	30	15	60	-	-	-	-	-	-	-	-	-	-	-	-	-	-	-	-	-	-	-	-	-	-	-	-	-	-	-	-	-	-	-	-
Vernon	•High frequency service would be provided for all new Line 105 stops •Underutilized bus stops would be consolidated to balance speed, reliability and accessibility.	6	12	7.5	20	60	60	10	10	10	15	30	60	15	15	13	25	60	60	15	15	15	30	30	60	25	16	16	35	60	60	15	15	15	30	30	60
R106	Line 106 between East LA College and LA County USC Medical Center via East LA and Boyle Heights is significantly upgraded: •New Line 106 would extend south via Atlantic Bl to Gold Line Atlantic Station •New Line 106 would replace Line 71 and extend east via Marengo St, Wabash St, City Terrace Dr to Cal State University LA. •New Line 106 would travel direct via 1st St instead of deviating via Indiana St, 3rd St, 4th St (Line 605 and Montebello Bus Lines 40), Soto St (Line 251), Whittier Bl (line 18) and Boyle Av •New Line 106 would operate very frequent service and implement new weekend service. •Underutilized bus stops would be consolidated to balance speed, reliability and accessibility.	50	50	50	50	-	-	15	15	15	30	60	-	-	-	-	-	-	-	30	15	15	30	60	-	-	-	-	-	-	-	30	15	15	30	60	-
R108	New Line 108: Merge Lines 108 & 358 via Slauson Ave between Culver City Transit Center and Pico Rivera: •Discontinue Lines 108 & 358 due to underutilization west of Sepulveda Bl to Marina Del Rey via Jefferson Bl, Centinela Av, Admiralty Way, Via Marina, Pacific Av as well as the deviation into Fox Hills Business Park. Alternative bus service will be available on Culver City Lines 2, 4, 7 and Big Blue Bus Line 18	8	15	9	25	60	-	15	15	15	15	30	60	15	15	15	40	60	-	15	15	15	30	60	60	25	20	20	60	60	-	15	15	15	30	60	60
R358	•New Line 108 would extend east to Slauson/Rosemead to connect with Line 256	15	-	15	-	-	-	-	-	-	-	-	-	-	-	-	-	-	-	-	-	-	-	-	-	-	-	-	-	-	-	-	-	-	-	-	-
RS108	•More frequency at all bus stops on Slauson Av and provide Overnight Owl service	-	-	-	-	-	-	15	15	15	-	-	-	-	-	-	-	-	-	-	-	-	-	-	-	-	-	-	-	-	-	-	-	-	-	-	-
Slauson	•Underutilized bus stops on Slauson Av would be consolidated to balance speed, reliability, and accessibility	6	15	6	25	60	-	7.5	7.5	7.5	15	30	60	15	15	15	40	60	-	15	15	15	30	60	60	25	20	20	60	60	-	15	15	15	30	60	60
R110	Line 110 will continue to serve the existing route from Playa Vista to Bell Gardens. •At the eastern end at Gage/Garfield, buses would stay on Garfield Av and not serve Foster Bridge Bl, Scout Av, and Florence Pl due to underutilized service. •More frequency during the midday and evening hours on weekdays.	10	20	15	40	60	-	15	15	15	30	60	-	25	20	25	40	60	-	30	30	30	30	60	-	40	35	35	50	60	-	30	30	30	30	60	-
R111	Line 111 will remain unchanged.	10	15	10	20	35	60	15	20	15	15	30	60	15	15	15	30	35	60	15	15	15	30	30	60	17	12	12	35	32	60	15	15	15	30	30	60
RS111	New overnight Owl service to serve the full route between Green Line Norwalk Station and LAX City Bus Center.	-	-	-	-	-	-	15	20	15	-	-	-	-	-	-	-	-	-	-	-	-	-	-	-	-	-	-	-	-	-	-	-	-	-	-	-
Florence		-	-	-	-	-	-	7.5	10	7.5	15	30	60	-	-	-	-	-	-	15	15	15	30	30	60	-	-	-	-	-	-	15	15	15	30	30	60
R115	New Line 115 would provide service from Westchester to Norwalk Station via Manchester Ave and Firestone Bl. Service to Playa del Rey would be discontinued west of Manchester/Sepulveda except selected school term trips, due to underutilized service. New Line 115 would provide new Overnight Owl Service.	10	15	10	35	60	-	12	12	12	15	30	60	22	20	20	35	60	-	20	20	20	30	60	60	30	20	20	45	60	-	20	20	20	30	60	60
R117	Line 117 from LAX City Bus Center to Lakewood Blvd Green Line Station would continue to travel via Century Blvd, Tweedy Blvd, and Imperial Hwy. Near Jordan Downs Housing Complex, Line 117 would be rerouted more directly from 103rd St to Century Blvd between Alameda St and Grape St. Line 117 would offer New Overnight Owl service.	15	20	15	35	60	-	15	15	15	30	60	60	30	25	25	50	60	-	30	30	30	30	60	60	30	30	30	35	60	-	30	30	30	30	60	60

Line	Service Change Proposal	Existing Weekday Frequency						Proposed Weekday Frequency						Existing Saturday Frequency						Proposed Saturday Frequency						Existing Sunday Frequency						Proposed Sunday Frequency									
		AM Peak	Midday	PM Peak	Evening	Late Night	Owl	AM Peak	Midday	PM Peak	Evening	Late Night	Owl	AM Peak	Midday	PM Peak	Evening	Late Night	Owl	AM Peak	Midday	PM Peak	Evening	Late Night	Owl	AM Peak	Midday	PM Peak	Evening	Late Night	Owl	AM Peak	Midday	PM Peak	Evening	Late Night	Owl				
R120	New Line 120 would provide service from Aviation/LAX Green Line Station to Green Line Norwalk Station via Imperial Hwy. Shortening Line 120 would allow it to operate more reliably.	40	30	30	45	60	-	30	30	30	30	60	-	55	60	60	60	60	60	-	60	60	60	60	60	60	-	55	60	60	60	60	60	-	60	60	60	60	60	60	-
R621	New Line 621 would replace Line 120 east from Norwalk Green Line Station to Whittwood Mall. In Downey, new Line 120 would remain on Imperial Hwy and not deviate into the Leeds St parking lot at the Rancho Los Amigos National Rehabilitation Center, this will provide faster more direct service.	-	-	-	-	-	-	60	60	60	60	-	-	-	-	-	-	-	-	-	60	60	60	60	-	-	-	-	-	-	-	-	-	60	60	60	60	-	-		
Imperial	Alternative bus service to the Leeds St parking lot remains available via Willowbrook/Rosa Parks Shuttle and Access Services.	-	-	-	-	-	-	30	30	30	30	60	-	-	-	-	-	-	-	-	60	60	60	60	60	60	-	-	-	-	-	-	-	-	60	60	60	60	60	60	-
R125	Line 125 would continue to operate between Norwalk Green Line Station and El Segundo via Rosecrans Ave. Line 125 would offer new Overnight Owl Service. Line 126 would be discontinued due to underutilized service.	14	35	25	60	-	-	20	20	20	30	60	60	40	30	30	60	-	-	30	30	30	30	60	60	60	30	40	60	-	-	30	30	30	30	60	60				
R126	Nearest alternative services would be available as follows: •Torrance Transit Line 8 (Aviation Bl) •Beach Cities Transit Line 109 •LADOT Commuter Express 438 (Highland Av) •Metro Lines 125 (Rosecrans Av) •Metro Line 210 (Crenshaw Bl) •Metro Line 212 (Hawthorne Bl) •Metro Line 232 (Sepulveda Bl) •G-Trans Line 5 (El Segundo Bl)	35	-	70	-	-	-	-	-	-	-	-	-	-	-	-	-	-	-	-	-	-	-	-	-	-	-	-	-	-	-	-	-	-	-	-	-				
R127	New Line 127 would follow the existing Line 127 route between A Line (Blue) Compton Station and Downey Depot, except for remaining on Somerset Blvd between Clark Av and Bellflower Bl.	60	60	60	-	-	-	30	30	30	30	60	-	-	-	-	-	-	-	60	60	60	60	60	60	-	-	-	-	-	-	-	60	60	60	60	60	60	-		
RS127	Service will be discontinued on Alondra Bl due to underutilized service in that segment and to make the route more direct. New Line 127 would be extended west of the A Line (Blue) Compton Station to the Harbor Freeway Station via Compton Bl, San Pedro St, El Segundo Bl, and Broadway to Figueroa/117th St, replacing a segment of Line 45 and existing Line 51.	-	-	-	-	-	-	30	30	30	-	-	-	-	60	60	-	-	-	-	60	60	-	-	-	-	-	60	60	-	-	-	-	60	60	-	-	-			
Compton	New weekend service and more frequent weekday service would be provided.	-	-	-	-	-	-	15	15	15	30	60	-	-	-	-	-	-	-	60	30	30	60	60	60	-	-	-	-	-	-	-	60	30	30	60	60	60	-		
R128	Line 128 between A Line (Blue) Compton Station and Cerritos Towne Center via Alondra Bl will change as follows: •Existing Line 128 segment south of Alondra Bl & Carmanita Rd will be discontinued due to underutilized service. •Alternative service to Cerritos Towne Center available via Cerritos On Wheels (COW) Route 1-A	35	55	55	60	-	-	60	60	60	60	-	-	-	-	-	-	-	-	60	60	60	60	-	-	-	-	-	-	-	-	60	60	60	60	-	-				
R130	Line 130 would continue to operate on Artesia Bl between the A (Blue) Line Artesia Station and Cerritos with new Overnight Owl service provided to improve late night and early morning trips. This segment of Line 130 would be operated initially by Metro and later transitioned to be operated by Long Beach Transit.	25	50	30	55	-	-	30	30	30	30	60	60	60	60	60	60	-	-	60	60	60	60	60	60	60	60	60	60	60	-	-	60	60	60	60	60	60	60		
R344	Line 130 west of the Artesia A (Blue) Line Station would transition to be operated by Torrance Transit as their new Line 13, following its existing route via Artesia Bl to Redondo Beach. Line 344 would operate via the existing route and stops via Artesia Bl and Hawthorne Bl to a new southern terminus at Hawthorne/Silver Spur. Service would be discontinued south of Silver Spur Rd to Rancho Palos Verdes due to underutilized service. Select alternative service is available by Palos Verde Peninsula Transit Authority.	20	60	20	60	-	-	30	30	30	30	30	-	35	40	40	60	-	-	60	60	60	60	60	60	-	60	60	60	60	-	-	60	60	60	60	60	60	-		
R150	New Lines 150 and 240: Merge Lines 150, 240 and 750: •New Line 150 would operate frequent service from Ventura/Reseda west to Chatsworth Station along Ventura Bl and Topanga Canyon Bl (replacing Line 245 segment) •New Line 240 would operate frequent service on the existing alignment between Northridge and Universal City/Studio City Station on Ventura Bl and Reseda Bl	20	22	24	40	60	60	20	20	20	30	60	-	20	30	30	40	40	60	30	30	30	30	60	60	30	35	35	40	40	60	30	30	30	30	60	60				
R750	•More frequent service at all new Line 150 and 240 bus stops •Underutilized bus stops would be consolidated on new Line 150 and 240 to balance speed, reliability, and accessibility.	15	30	15	30	-	-	-	-	-	-	-	-	-	-	-	-	-	-	-	-	-	-	-	-	-	-	-	-	-	-	-	-	-	-	-	-				
R240	•More frequent service at all new Line 150 and 240 bus stops •Underutilized bus stops would be consolidated on new Line 150 and 240 to balance speed, reliability, and accessibility.	25	32	24	40	40	60	10	10	10	15	30	60	30	20	10	35	40	60	15	15	15	15	30	60	30	35	35	40	40	60	15	15	15	15	30	60				
Reseda/Ventura		7.5	9	7	12	24	30	10	10	10	15	30	60	12	12	7.5	20	20	30	15	15	15	15	30	60	15	17	17	20	20	30	15	15	15	15	30	60				
R152	Line 152: Merge Lines 152 & 353: •New Line 152 would continue to serve Roscoe Bl with proposed frequency improvements midday weekdays •On the east end, new Line 152 is proposed to travel via Lankershim Bl to provide a more direct connection to the Red Line North Hollywood Station.	20	25	25	35	60	-	15	15	15	30	60	60	25	25	25	60	60	-	30	20	20	30	60	60	35	30	30	60	60	-	30	20	20	30	60	60				
R353	•Service on Vineland Ave would be provided by modified Lines 162 and new Line 290 (please see Line 162 and Line 290 information sheets) •The route is proposed to terminate at Topanga Canyon Bl in the west end. A modified Line 162 would provide service on Fallbrook Av	20	-	25	-	-	-	-	-	-	-	-	-	-	-	-	-	-	-	-	-	-	-	-	-	-	-	-	-	-	-	-	-	-	-	-	-				
Roscoe		10	25	13	35	60	-	15	15	15	30	60	60	25	25	25	60	60	-	30	20	20	30	60	60	35	30	30	60	60	-	30	20	20	30	60	60				
R153	New Line 153 would operate between the Red Line North Hollywood Station and downtown Burbank via Burbank Bl, as well as an existing segment of Burbank Bl east of the Red Line North Hollywood Station.	-	-	-	-	-	-	30	30	30	30	30	-	-	-	-	-	-	-	60	30	30	30	60	-	-	-	-	-	-	-	60	30	30	30	60	-				
R154	Line 154 would operate between the Red Line North Hollywood Station and Sepulveda Bl, via Oxnard St and Burbank Bl as a two-way direction circulator: •More frequency on the new proposed route •Discontinue service west of Sepulveda Bl due to underutilized service	60	65	64	-	-	-	30	30	30	30	-	-	-	-	-	-	-	-	60	60	60	60	-	-	-	-	-	-	-	-	60	60	60	60	-	-				
R155	New Line 155 will merge existing Line 155 with a segment of Line 183: •New Line 155 would operate via Riverside Dr, Sepulveda Bl, and Magnolia Bl between the Red Line North Hollywood Station and Red Line Universal City/Studio City Station •Segment of Line 155 east of Universal City/Studio City Station via Olive Ave would continue to be served by Burbank Bus newly improved Pink Route	42	45	45	60	-	-	30	30	30	30	-	-	50	50	50	50	-	-	60	60	60	60	-	-	60	60	60	60	-	-	60	60	60	60	-	-				
R158	New Line 158 would follow the existing Line 158 via Woodman Av, then travel via Plummer St to Chatsworth Station, while new Line 167 would serve the current Line 158 segment on Devonshire St. •This swap of east-west alignments between Lines 158 and 167 is intended to create simpler, easier to use Lines 158 and 167 •Service to Sepulveda Ambulatory Care Center would be provided on-street at Haskell Av and Gloria Av	22	60	50	60	-	-	60	60	60	60	-	-	60	60	60	60	-	-	60	60	60	60	-	-	60	50	50	55	-	-	60	60	60	60	-	-				
R161	Line 161 would operate primarily on the existing route between Orange Line Canoga Station and City of Thousand Oaks: •In Calabasas, Line 161 would operate on Calabasas Rd instead of Park Calabasas and Park Granada to improve travel time	20	60	35	55	-	-	60	60	30	60	-	-	60	60	60	60	-	-	60	60	60	60	-	-	60	65	65	60	-	-	60	60	60	60	-	-				
R162	New Line 162: Merge Line 162 & Line 163: •More frequency during the mid-day on weekdays on Sherman Way •On the east end, new Line 162 would be routed via Vineland Av to provide more service along that corridor while still connecting to Red Line North Hollywood Station	20	40	20	50	60	-	15	15	15	20	30	60	50	60	60	60	60	-	30	30	30	30	30	60	50	60	60	-	-	30	30	30	30	30	60					
R163	•Line 152 would serve Lankershim Bl. (see Line 152 information sheet) •New Line 162 would be extended to serve Fallbrook Av in the west end •Line 169 would continue to directly serve West Hills Medical Center (see Line 169 information sheet)	20	40	30	60	60	-	-	-	-	-	-	-	50	60	60	60	60	-	-	-	-	-	-	-	50	60	60	60	60	-	-	-	-	-	-	-				
Sherman Way		10	20	12	30	30	-	15	15	15	20	30	60	25	30	30	30	30	30	30	30	30	30	60	25	30	30	60	60	30	30	30	30	30	60						
R164	Line 164 would operate in partnership with Line 165, with buses changing between each Line at Platt Ave/Victory Bd (to eliminate a long turn-around loop and reinvest into more frequent service). Line 164 would operate more frequency during the midday hours on weekdays.	12	30	15	35	60	-	15	15	15	30	60	-	30	30	30	40	60	-	30	30	30	30	60	60	35	35	30	60	60	-	30	30	30	30	60	60				
R165	Line 165 would operate in partnership with Line 164, with buses changing between each Line at Platt Ave/Victory Bd (to eliminate a long turn-around loop and reinvest into more frequent service).	6.5	30	10	30	60	-	15	15	15	30	60	-	40	35	35	60	60	-	30	30	30	30	60	60	40	40	40	40	60	-	30	30	30	30	60	60				
R166	New Line 166: Merge Lines 166 & 364: •Would continue to serve Nordhoff St and Osborne St •Would operate more frequent midday weekday service •New Line 166 would extend east via Osborne St and Foothill Bl to Hansen Dam and Discovery Cube, making connections with New Line 690 on Foothill Bl •A short segment of Glenoaks Bl would then be served by Line 92	15	24	15	40	60	-	15	15	15	30	60	60	35	35	35	60	-	-	30	30	30	30	60	60	40	40	40	40	-	-	30	30	30	30	60	60				
R364		15	-	15	-	60	-	-	-	-	-	-	-	-	-	-	-	-	-	-	-	-	-	-	-	-	-	-	-	-	-	-	-	-	-	-	-				

Line	Service Change Proposal	Existing Weekday Frequency						Proposed Weekday Frequency						Existing Saturday Frequency						Proposed Saturday Frequency						Existing Sunday Frequency						Proposed Sunday Frequency					
		AM Peak	Midday	PM Peak	Evening	Late Night	Owl	AM Peak	Midday	PM Peak	Evening	Late Night	Owl	AM Peak	Midday	PM Peak	Evening	Late Night	Owl	AM Peak	Midday	PM Peak	Evening	Late Night	Owl	AM Peak	Midday	PM Peak	Evening	Late Night	Owl	AM Peak	Midday	PM Peak	Evening	Late Night	Owl
Nordhoff	<ul style="list-style-type: none"> On the west end, New Line 166 is proposed to end at Nordhoff St/Canoga Av, with access to Chatsworth Station via the Metro Orange Line A segment on Topanga Canyon Blvd would continue to be served by new Line 150 New Line 158 would follow the existing Line 158 via Woodman Av, then travel via Plummer St to Chatsworth Station, while new Line 167 would serve the current Line 158 segment on Devonshire St. This swap of east-west alignments between Lines 158 and 167 is intended to create simpler, easier to use Lines 158 and 167 Service to Sepulveda Ambulatory Care Center would be provided on-street at Haskell Av and Gloria Av 	7.5	24	7.5	40	60	-	15	15	15	30	60	60	35	35	35	60	-	-	30	30	30	30	60	60	40	40	40	40	-	-	30	30	30	30	60	60
R167	<ul style="list-style-type: none"> New Line 169 would operate on Satcoy St between Lankershim Bl and West Hills Medical Center. The east end of new Line 169 would end at Satcoy St/Lankershim Bl due to underutilized service east of Lankershim Bl. Discontinue the segment south of West Hills Medical Center due to underutilized service Additional trips serving El Camino High School would be maintained More weekday frequency and new weekend service would be provided between Lankershim Bl and Fallbrook Av 	40	40	55	60	60	-	60	60	60	60	60	-	50	40	60	60	60	-	60	60	60	60	60	-	50	40	60	60	60	-	60	60	60	60	60	-
R169	<ul style="list-style-type: none"> New Line 169 would operate on Satcoy St between Lankershim Bl and West Hills Medical Center. The east end of new Line 169 would end at Satcoy St/Lankershim Bl due to underutilized service east of Lankershim Bl. Discontinue the segment south of West Hills Medical Center due to underutilized service Additional trips serving El Camino High School would be maintained More weekday frequency and new weekend service would be provided between Lankershim Bl and Fallbrook Av 	10	60	25	60	-	-	30	30	30	30	-	-	-	-	-	-	-	-	60	60	60	60	-	-	-	-	-	-	-	-	60	60	60	60	-	-
R175	Replace Line 201 weekday service between Koreatown and Glendale via Silver Lake with frequent service on Fletcher Dr, Rowena Av, and Franklin St (see New Line 83 information sheet), Glendale Bl (Line 92) and Sunset Av (new Lines 2 and 4).	15	-	60	60	-	-	-	-	-	-	-	-	-	-	-	-	-	-	-	-	-	-	-	-	-	-	-	-	-	-	-	-	-	-	-	-
R201	Discontinue Line 176 weekday service between Highland Park and El Monte Bus Station due to underutilized service and overlap of Metro Lines 78, 258, 260, 266 and 267, Montebello Bus Lines 20 and 30, and Foothill Transit Line 487.	55	55	54	54	-	-	-	-	-	-	-	-	60	70	70	66	-	-	-	-	-	-	-	-	55	70	70	66	-	-	-	-	-	-	-	-
R176	Discontinue Line 176 weekday service between Highland Park and El Monte Bus Station due to underutilized service and overlap of Metro Lines 78, 258, 260, 266 and 267, Montebello Bus Lines 20 and 30, and Foothill Transit Line 487.	40	45	45	50	-	-	-	-	-	-	-	-	-	-	-	-	-	-	-	-	-	-	-	-	-	-	-	-	-	-	-	-	-	-	-	-
R177	Pasadena Transit would operate weekday peak period service between Pasadena and the Jet Propulsion Laboratory in place of Metro, with a minor reroute proposed in Pasadena to use Mountain St instead of Walnut St.	30	-	30	60	-	-	-	-	-	-	-	-	-	-	-	-	-	-	-	-	-	-	-	-	-	-	-	-	-	-	-	-	-	-	-	-
R180	New Frequent Line 180: Merge Lines 180, 181, 217, 780	30	60	30	50	60	60	7.5	7.5	7.5	10	30	60	24	36	24	40	-	-	15	15	15	15	60	60	50	24	24	50	-	-	15	15	15	15	60	60
R181	New Line 180 would operate between Pasadena, Glendale, Hollywood via Colorado Bl, Broadway, Los Feliz Bl, Hollywood Bl, Fairfax Av, following existing Lines 217, 180, 181 between La Cienega/Jefferson Expo Line Station and Pasadena City College.	30	60	30	50	60	-	-	-	-	-	-	-	36	36	36	40	-	-	-	-	-	-	-	-	50	36	36	50	-	-	-	-	-	-	-	-
R780	Underutilized bus stops on new Line 180 would be consolidated to balance speed, reliability, and accessibility	10	20	12	60	-	-	-	-	-	-	-	-	-	-	-	-	-	-	-	-	-	-	-	-	-	-	-	-	-	-	-	-	-	-	-	-
R217	Discontinue Line 217 south of La Cienega/Jefferson Station to Westfield Culver City due to underutilized service	15	15	13	15	30	60	-	-	-	-	-	-	40	15	12	20	30	60	-	-	-	-	-	-	35	20	15	20	30	60	-	-	-	-	-	-
Colorado/Fairfax	<ul style="list-style-type: none"> Pasadena Transit Line 20 and New Line 662 would replace Line 180 on Lake Av Foothill Transit Line 187 would replace Line 181 service on Colorado Bl east of Pasadena City College 	6	7	9	9	30	60	7.5	7.5	7.5	10	30	60	12	18	12	20	-	-	15	15	15	15	60	60	25	12	12	25	-	-	15	15	15	15	60	60
R183	<ul style="list-style-type: none"> Merge Line 183 with a segment of Line 155: New Line 155 would operate via Riverside Dr, Sepulveda Bl, and Magnolia Bl between North Hollywood Station and Universal City/Studio City Station New Line 94 would provide more frequency on the segment of existing Line 183 east of Red Line North Hollywood Station along Magnolia Bl 	30	60	30	60	-	-	30	30	30	30	-	-	65	65	65	65	-	-	60	60	60	60	-	-	65	65	65	65	-	-	60	60	60	60	-	-
R202	<ul style="list-style-type: none"> New Line 202 would operate peak hours only weekdays via the existing Line 202 route between A (Blue) and Green Line and Imperial/Wilmington Rosa Parks Stations' to A Line (blue) Artesia Station. Discontinue service south of A Line (Blue) Artesia Station to Wilmington via Santa Fe Av, Victoria St, Susana Rd, Del Amo Bl and Alameda St due to underutilized service. Nearest alternative Metro service would be Line 205 (Wilmington Av), Line 232 (Anaheim St) and Line 246 (Avalon Bl). 	60	-	60	-	-	-	30	-	30	-	-	-	-	-	-	-	-	-	-	-	-	-	-	-	-	-	-	-	-	-	-	-	-	-	-	-
R204	New Line 204 would follow the existing route between Hollywood and the Green Line Vermont/Athens Station via Vermont Av.	10	15	10	20	30	30	5	5	5	10	15	30	20	20	15	20	30	30	7.5	7.5	7.5	10	15	30	20	20	15	20	30	30	7.5	7.5	7.5	10	15	30
R54	<ul style="list-style-type: none"> New Line R54 would provide more frequent midday and weekend service New Line R54 would provide more weekday peak service serving existing Line 754 stops More frequency would be provided for all New Line 204 bus stops on Vermont Ave Underutilized existing Line 204 bus stops would be consolidated to balance speed, reliability, and accessibility. 	6	15	6	20	-	-	10	-	10	-	-	-	12	12	12	20	-	-	-	-	-	-	-	-	25	15	20	30	-	-	-	-	-	-	-	-
Vermont	<ul style="list-style-type: none"> New Line 204 would provide faster service on a simpler route via Del Amo Bl between Wilmington Bl and Main St, serving new development and connecting with Silver Line service at Carson Transitway Station. This will eliminate out-of-direction service overlapping Line 246 on Avalon Bl to Harbor Gateway Transit Center Avoids service duplication of Torrance Transit Line 6 on Victoria St and Torrance Transit Line 1 on Vermont Av north of Carson St In San Pedro, new Line 205 would be simpler, serving 7th Street in both directions between Harbor Bl and Weymouth Av, and alternative service on 1st St and 13th St would be provided by DASH San Pedro 	4	7.5	4	10	30	30	5	5	5	10	15	30	7.5	7.5	7	10	30	30	7.5	7.5	7.5	10	15	30	12	8	8	12	30	30	7.5	7.5	7.5	10	15	30
R205	<ul style="list-style-type: none"> New Line 205 would provide faster service on a simpler route via Del Amo Bl between Wilmington Bl and Main St, serving new development and connecting with Silver Line service at Carson Transitway Station. This will eliminate out-of-direction service overlapping Line 246 on Avalon Bl to Harbor Gateway Transit Center Avoids service duplication of Torrance Transit Line 6 on Victoria St and Torrance Transit Line 1 on Vermont Av north of Carson St In San Pedro, new Line 205 would be simpler, serving 7th Street in both directions between Harbor Bl and Weymouth Av, and alternative service on 1st St and 13th St would be provided by DASH San Pedro 	25	30	35	50	60	-	30	30	30	30	60	-	50	55	60	60	60	-	60	60	60	60	-	-	55	60	60	60	60	-	60	60	60	60	-	-
R206	Line 206 will continue to serve Normandie Av between Red Line Vermont/Sunset Station and Green Line Vermont/Athens Station, with no proposed route changes, and more frequency during the midday hours on weekdays.	8	20	12	20	60	-	10	15	10	15	30	-	20	20	20	30	60	-	20	20	20	20	30	-	20	20	20	30	60	-	20	20	20	20	30	-
R207	New High Frequency Line 207: Merge Lines 207 and 757	10	15	10	20	20	60	6	7.5	6	12	15	30	12	12	10	15	20	60	12	12	12	15	15	30	15	12	12	20	35	60	12	12	12	15	15	30
R757	New Line 207 would operate between Hollywood and the Green Line Crenshaw Station:	10	15	8	-	-	-	-	-	-	-	-	-	-	-	-	-	-	-	-	-	-	-	-	-	-	-	-	-	-	-	-	-	-	-	-	-
Western	<ul style="list-style-type: none"> More frequency for all new Line 207 bus stops on Western Av Underutilized bus stops would be consolidated on Western Av to balance speed, reliability, and accessibility. 	5	7.5	6	20	20	60	6	7.5	6	12	15	30	12	12	10	15	20	60	12	12	12	15	15	30	15	12	12	20	35	60	12	12	12	15	15	30
R209	<ul style="list-style-type: none"> Discontinue Line 209 on Van Ness Ave and Arlington Av due to underutilized service. Alternative service is available on nearby Western Av (Metro Line 207) and Western and Vermont Av (G-Trans Line 2). 	50	60	50	60	-	-	-	-	-	-	-	-	-	-	-	-	-	-	-	-	-	-	-	-	-	-	-	-	-	-	-	-	-	-	-	-
R210	New High Frequency Line 210: Merge Lines 210 & 710	15	20	15	30	60	-	10	10	10	15	30	60	30	20	20	20	60	-	10	10	10	15	30	60	25	15	15	30	60	-	10	10	10	15	30	60
R610	New Line 210 would operate via Crenshaw Bl between Crenshaw/Wilshire and Crenshaw/Redondo Beach and via Redondo Beach Bl to South Bay Galleria:	-	-	-	-	-	-	15	15	15	30	30	-	-	-	-	-	-	15	15	15	30	30	-	-	-	-	-	-	-	15	15	15	30	30	-	
R710	<ul style="list-style-type: none"> More frequency would be provided for all bus stops on Crenshaw Bl. Underutilized bus stops on Crenshaw Bl would be consolidated to balance speed, reliability, and accessibility. Torrance Transit Line 2 would replace the existing Line 210 segment on Crenshaw Bl and Artesia Bl south of El Camino College 	10	20	10	20	-	-	-	-	-	-	-	-	20	20	20	20	-	-	-	-	-	-	-	-	-	-	-	-	-	-	-	-	-	-	-	-
Crenshaw	<ul style="list-style-type: none"> New Metro Line 610 would replace existing Line 210 north of Wilshire Bl via Rossmore Av and Vine St to Red Line Hollywood/Vine Station New Line 210 would provide new Late Night Owl service 	6	10	6	12	60	-	10	10	10	15	30	60	12	10	10	10	60	-	10	10	10	15	30	60	25	15	15	30	60	-	10	10	10	15	30	60
R211	<ul style="list-style-type: none"> New Lines 211 and 215 would operate as separate two-directional loop routes serving north (new Line 211) and south (new Line 215) of the Green Line Hawthorne/Lennox Station. Service would provide new midday weekday, night and weekend service on both lines: New Line 211 loop would replace Line 212/312 on Prairie Av (Line 212 would instead serve Hawthorne Bl) and New Line 211 would also replace Line 215 service on Manchester Av and Inglewood Av north of the Green Line New Line 215 loop would replace existing Lines 211 and 215 south of the Green Line on Prairie Av, Marine Av, and Inglewood Av 	30	-	30	-	-	-	30	30	30	30	60	-	-	-	-	-	-	-	60	60	60	60	60	-	-	-	-	-	-	-	60	60	60	60	60	-
R215	<ul style="list-style-type: none"> New Lines 211 and 215 would operate as separate two-directional loop routes serving north (new Line 211) and south (new Line 215) of the Green Line Hawthorne/Lennox Station. Service would provide new midday weekday, night and weekend service on both lines: New Line 211 loop would replace Line 212/312 on Prairie Av (Line 212 would instead serve Hawthorne Bl) and New Line 211 would also replace Line 215 service on Manchester Av and Inglewood Av north of the Green Line New Line 215 loop would replace existing Lines 211 and 215 south of the Green Line on Prairie Av, Marine Av, and Inglewood Av 	30	-	30	-	-	-	30	30	30	30	60	-	-	-	-	-	-	-	60	60	60	60	60	-	-	-	-	-	-	-	60	60	60	60	60	-

Line	Service Change Proposal	Existing Weekday Frequency						Proposed Weekday Frequency						Existing Saturday Frequency						Proposed Saturday Frequency						Existing Sunday Frequency						Proposed Sunday Frequency					
		AM Peak	Midday	PM Peak	Evening	Late Night	Owl	AM Peak	Midday	PM Peak	Evening	Late Night	Owl	AM Peak	Midday	PM Peak	Evening	Late Night	Owl	AM Peak	Midday	PM Peak	Evening	Late Night	Owl	AM Peak	Midday	PM Peak	Evening	Late Night	Owl	AM Peak	Midday	PM Peak	Evening	Late Night	Owl
Soto	underutilized service and duplication of service from other lines. The following alternative bus service would be available: Figueroa St (Line 81); Pasadena Av (new Line 182); Broadway (Line 45); Huntington Dr (Line 78), Valley Bl (Line 76), and Soto St (Line 51).	7.5	10	9	15	50	60	10	10	10	15	30	60	15	12	12	40	50	60	15	15	15	30	30	60	25	15	15	40	50	60	15	15	15	30	30	60
R254	Line 254 would be discontinued between East LA and Watts via Boyle Av and Lorena St due to underutilized service and duplication of service from other lines. The following alternative bus services would be available: 103rd St (Line 117), Compton Av (Line 55); Firestone Bl (Line 115); Florence Av (Line 111); Pacific Bl (Lines 60, 251); Gage Av (Line 110); Lorena Av (Line 605); Indiana St (Line 665).	35	70	70	-	-	-	-	-	-	-	-	-	60	60	60	-	-	-	-	-	-	-	-	-	-	-	-	-	-	-	-	-	-	-	-	-
R256	Line 256 between Commerce and Altadena via El Sereno, Highland Park, and Pasadena would be subdivided by three separate bus lines with more frequent service: •City of Commerce would operate the existing segment between Commerce and Cal State LA Station, with no proposed changes to alignment •Metro would continue to operate the existing segment between Cal State LA Station and Gold Line Highland Park Station as Line 256, with no proposed changes to alignment •Pasadena Transit would operate a simpler route between Highland Park and Pasadena, via Colorado Bl, Gold Line Memorial Park Station, Lincoln Ave, Washington Bl, Altadena Dr and Foothill Bl to Sierra Madre Villa Station •New Line 662 would serve Lake Av between Pasadena and Altadena, with Metro Lines 180, 686 and Foothill Transit 187 serving Colorado Bl in Pasadena	50	50	50	45	-	-	20	30	30	30	30	-	60	60	60	60	-	-	40	40	40	40	-	-	60	60	60	60	-	-	40	40	40	40	-	-
R258	Line 258 would be shortened between Paramount and Altadena via South Gate, Bell Gardens, Commerce, East LA, Monterey Park, Alhambra and Pasadena on Eastern Av, Fremont Av, and Lake Av to improve reliability and avoid duplication of other bus service. This would provide a much-requested connection with the Gold Line South Pasadena Station via Fremont Av and Fair Oaks Av: •Service would be discontinued on Huntington Dr/Oak Knoll Av-Cir in San Marino due to underutilized Line 258 service •New Metro Line 662 would operate two-directional service on Lake Av, Altadena Dr, Lincoln Av, Washington Bl, and Los Robles Av between Pasadena (Gold Line Del Mar and Lake Stations) and Altadena •New Lines 258 and 662 would both provide new weekend service	40	40	40	60	-	-	40	40	40	40	60	-	-	-	-	-	-	-	60	60	60	60	60	-	-	-	-	-	-	-	60	60	60	60	60	-
R260	New Line 260: Merge Lines 260 & 762 between Altadena, Pasadena, Alhambra, East LA, Lynwood and Compton via Fair Oaks Av and Atlantic Bl; would provide more frequent and more reliable service following the existing Line 260/762 route between Gold Line Memorial Park Station and Imperial Highway then travel west to Willowbrook/Rosa Parks A (Blue) & Green Line Station:	15	20	15	20	60	-	12	12	12	15	30	60	20	20	20	40	60	-	20	20	20	30	30	60	30	20	20	30	60	-	20	20	20	30	30	60
R261		-	-	-	-	-	-	15	15	15	15	30	-	-	-	-	-	-	-	30	30	30	30	60	-	-	-	-	-	-	-	30	30	30	30	60	-
R660		-	-	-	-	-	-	15	15	15	15	30	-	-	-	-	-	-	-	15	15	15	15	30	-	-	-	-	-	-	-	15	15	15	15	30	-
R762	•A new frequent Line 261 would link A (Blue) Line & Green Line Willowbrook/Rosa Parks A (Blue) Station and A (Blue) Line Artesia Station via Imperial Hwy, Atlantic Bl, and Artesia Bl •A new frequent Line 660 would operate between Gold Line Memorial Park Station and Altadena via Fair Oaks Av	25	30	25	60	-	-	-	-	-	-	-	-	-	-	-	-	-	-	-	-	-	-	-	-	-	-	-	-	-	-	-	-	-	-	-	-
Atlantic		10	12	10	15	60	-	12	12	12	15	30	60	20	20	20	40	60	-	15	15	15	15	30	60	30	20	20	30	60	-	15	15	15	15	30	60
R264	Line 264 would be discontinued between Duarte, Monrovia, Arcadia, Pasadena, Altadena via Duarte Rd, Michillinda Ave, Foothill Bl, Altadena Dr due to underutilized service and duplication of service of other bus lines: •New Line 256 (Pasadena Transit) would serve Altadena Dr (south of Washington Bl) and Foothill Bl, with new Line 662 serving Altadena Dr at Lake Av •Nearest alternative service in Duarte and Monrovia would be Metro Gold Line, Foothill Transit on Buena Vista St (Line 272) and Myrtle Av (Line 170), and Duarte Transit •Nearest alternative service to Arcadia-Sierra Madre Villa would be on Temple City Bl, Huntington Dr, Rosemead Bl, Michillinda Av (Metro Lines 266, 267, 268 and Foothill Transit Line 187) and on Baldwin Av/Huntington Dr (Metro Lines 78 and 268)	60	60	65	60	-	-	-	-	-	-	-	-	60	60	60	-	-	-	-	-	-	-	-	-	60	60	60	-	-	-	-	-	-	-	-	-
R267	Line 267 would be shortened between El Monte, Arcadia, Pasadena, and Altadena via Temple City Bl, Rosemead Bl, Del Mar Bl, Lincoln Av, and Altadena Dr to end at the Gold Line Del Mar Station in Pasadena. This would improve reliability and avoid service duplication with other bus lines: •Pasadena Transit would operate new Line 256 on southern end of Lincoln Ave with new Metro Line 662 serving the north end of Lincoln Av and Altadena Dr	30	30	30	25	-	-	30	30	30	30	-	-	60	60	60	-	-	-	60	60	60	60	-	-	60	60	60	-	-	-	60	60	60	60	-	-
R265	More frequent service would be provided during daytime hours on weekdays. Line 266 has no significant changes between Lakewood, Bellflower, Downey, Pico Rivera, South El Monte, Arcadia, Pasadena, and Altadena via Lakewood Bl and Rosemead Bl:	40	60	60	60	-	-	30	30	30	30	60	-	-	60	60	60	-	-	60	60	60	60	-	-	-	60	60	60	-	-	60	60	60	60	-	-
R266	•Line 266 would end on northbound Lakewood Bl adjacent to Lakewood Center Mall for improved connections with the mall and Line 265 •Line 266 would provide more frequent service during midday hours on weekdays and weekends	20	35	20	50	-	-	20	20	20	30	60	-	45	45	40	40	40	-	30	30	30	30	60	-	50	45	45	45	-	-	30	30	30	30	60	-
R268	Line 268 route would be shortened between El Monte, Arcadia, Sierra Madre, Pasadena, La Canada Flintridge (Jet Propulsion Lab), and Altadena via Baldwin Av, Sierra Madre Bl, Orange Grove Bl, and Washington Bl to end at the Gold Line Sierra Madre Villa Station to improve reliability and avoid service duplication of other bus lines: •Pasadena Transit would operate new Line 256 on southern end of Lincoln Ave, Washington Blvd, Altadena Dr, Foothill Bl to Sierra Madre Villa Station •New Metro Line 662 would serve the northern end of Lincoln and Washington Blvd west of Los Robles Av (see Line 662 information sheet) •Line 268 has very low utilization to JPL on weekends. Line 177 (to be operated by Pasadena Transit) would provide alternative service to JPL on the weekdays only during peak periods via connections to the Gold Line Del Mar & Memorial Park Stations. •Line 268 would provide more frequent service during midday hours on weekdays and weekends	30	50	30	50	-	-	30	30	30	30	60	-	60	60	50	50	-	-	60	60	60	60	60	-	60	60	60	60	-	-	60	60	60	60	60	-
R442	Express Line 442 would be discontinued due to underutilized service and service duplication with other bus lines. Alternative bus service would be available on Metro Silver Line to Manchester Station (connection with Line 115 on Manchester Bl) or Harbor Freeway Station (connection with Line 120 on Imperial Hwy or Green/Silver Line service).	40	-	40	-	-	-	-	-	-	-	-	-	-	-	-	-	-	-	-	-	-	-	-	-	-	-	-	-	-	-	-	-	-	-	-	-
R460	Line 460 would operate between downtown LA and Disneyland via I-110 Harbor Transitway, I-105, Green Line Norwalk Station, Rosecrans Av, Carmentia Rd, Alondra Bl, Beach Bl, I-5 and Harbor Bl	20	25	25	30	40	-	-	-	-	-	-	-	30	25	25	30	40	-	-	-	-	-	-	-	30	30	30	30	35	-	-	-	-	-	-	-
R160	Line 460 would operate as new Line 160 between Green Line Norwalk Station and Disneyland: •New Line 160 would not serve the existing Line 460 segment between downtown LA and Green Line Norwalk Station due to duplication of other service; alternative bus service for this segment would be available by utilizing the Silver Line, Blue Line and Green Line •New Line 160 would bypass Fullerton Park & Ride to provide faster, more direct service to Knott's Berry Farm in Buena Park and Disneyland in Anaheim, with alternative bus service available on OCTA Routes 30 and Bravo! 529	-	-	-	-	-	-	30	30	30	30	60	-	-	-	-	-	-	-	30	30	30	30	60	-	-	-	-	-	-	-	30	30	30	30	60	-
R487	New Line 487: frequent service would link the Gold Line Sierra Madre Villa Station and LA Union Station via San Gabriel Bl, Las Tunas Dr, Mission Dr, Del Mar Av, I-10 Express-Lanes: •Frequent Metro Red/Purple/Silver Line services would serve downtown LA and Westlake/MacArthur Park in place of Line 487 •New Line 287 would be introduced, serving existing Line 487 segment between El Monte Station and Gold Line Arcadia Station via Santa Anita Ave seven days a week •Existing Line 487 north and west of Gold Line Arcadia Station to Gold Line Sierra Madre Villa Station via Santa Anita Av, Sierra Madre Av, San Gabriel Av would be discontinued due to underutilized service, with alternative Metro Line 268 service available on Baldwin Av, Sierra Madre Bl and Michillinda Av	25	40	40	50	-	-	15	30	15	30	60	-	50	60	50	60	-	-	60	60	60	60	60	-	60	50	50	60	-	-	60	60	60	60	60	-
R287		-	-	-	-	-	-	30	30	30	30	60	-	-	-	-	-	-	-	60	60	60	60	60	-	-	-	-	-	-	-	60	60	60	60	60	-
R489		15	-	20	-	-	-	20	-	20	-	-	-	-	-	-	-	-	-	-	-	-	-	-	-	-	-	-	-	-	-	-	-	-	-	-	-
Santa Anita	Proposed Line 489 would link Arcadia and LA Union Station during peak hours on weekdays via Rosemead Bl, Valley Bl, Del Mar Av, I-10 Express Lanes: •Frequent Metro Red/Purple/Silver Line services would serve downtown LA and Westlake/MacArthur Park in place of Line 489 west of Union Station	-	-	-	-	-	-	8.5	30	8.5	30	60	-	-	-	-	-	-	-	60	60	60	60	60	-	-	-	-	-	-	-	60	60	60	60	60	-

Line	Service Change Proposal	Existing Weekday Frequency						Proposed Weekday Frequency						Existing Saturday Frequency						Proposed Saturday Frequency						Existing Sunday Frequency						Proposed Sunday Frequency								
		AM Peak	Midday	PM Peak	Evening	Late Night	Owl	AM Peak	Midday	PM Peak	Evening	Late Night	Owl	AM Peak	Midday	PM Peak	Evening	Late Night	Owl	AM Peak	Midday	PM Peak	Evening	Late Night	Owl	AM Peak	Midday	PM Peak	Evening	Late Night	Owl	AM Peak	Midday	PM Peak	Evening	Late Night	Owl			
R501	Line 501 would continue to link North Hollywood, Burbank, Glendale, and Pasadena, with the following changes: •A new route for Line 501 is proposed in Burbank to simplify and expedite service through the Media District by operating on Alameda Av instead of Olive Av •A new route for Line 501 would operate in downtown Glendale via Brand Bl and Broadway with a new Line 501 stop to serve the Americana at Brand and Glendale Galleria •A new route and stop for Line 501 would serve the LA Zoo and Griffith Park	12	30	12	25	-	-	15	30	15	30	-	-	45	45	45	45	-	-	30	30	30	30	-	-	45	45	45	45	-	-	30	30	30	30	-	-			
R534 R134	New Line 134: Line 534 would be renumbered to 134. There are no route changes for New Line 134 between Malibu and Santa Monica.	20	60	30	50	-	-	-	-	-	-	-	-	25	60	30	50	-	-	-	-	-	-	-	-	60	60	45	60	-	-	-	-	-	-	-	-			
R550	Express Line 550 would be discontinued due to underutilized service and service duplication with other bus lines. Alternative bus service would be provided by Metro E Line (Expo) and Silver Line 910, Torrance Transit Line 1 on Vermont Av from Harbor Gateway Transit Center, and Metro Line 205 on Vermont Ave and 7th St in San Pedro from Carson Transitway Station.	30	60	30	60	-	-	-	-	-	-	-	-	60	60	60	60	60	-	-	-	-	-	-	-	-	60	60	60	60	60	-	-	-	-	-	-	-	-	
R577	Line 577 between El Monte Station and Cal State Long Beach via I-605 would change as follows: •Reroute service between El Monte Station and Rio Hondo College via the I-10 and I-605 freeways instead of Santa Anita Ave and Peck Rd, providing faster and more direct service •Discontinue the deviation to Los Cerritos Center due to low ridership, providing faster and more direct service to/from Cal State Long Beach and VA	40	45	40	50	-	-	30	30	30	60	60	-	-	-	-	-	-	-	-	-	-	-	-	-	-	-	-	-	-	-	-	-	-	-	-	-	-		
R603	Line 603 would continue on the current route between Glendale Galleria and downtown LA, with more frequent service during the midday hours on weekdays: •Line 603 would be rerouted via Glendale Station, providing direct connections with Metrolink and Amtrak.	10	20	12	25	-	-	12	12	12	15	30	-	-	25	20	15	20	-	-	20	20	20	20	30	-	-	30	20	15	20	-	-	20	20	20	20	30	-	-
R605	Line 605 would operate between LA County USC Medical Center and Olympic Bl/Grande Vista Av and be extended west on 8th St to end at Olympic Bl/Soto St, improving connections with Lines 66, 251, and 665. Line 605 would provide more frequency during midday hours on weekdays and weekends.	15	25	15	-	-	-	15	15	15	30	30	-	-	30	35	35	-	-	-	20	20	20	30	30	-	-	30	35	35	-	-	-	20	20	20	30	30	-	-
R607	Line 607 would be discontinued due to underutilized service. Nearest alternative bus service would be on Slauson Av (Line 108), Hyde Park Bl (Line 110), Manchester Av (Line 115), Crenshaw Bl (Line 210), and La Brea Av (Line 212).	60	-	60	-	-	-	-	-	-	-	-	-	-	-	-	-	-	-	-	-	-	-	-	-	-	-	-	-	-	-	-	-	-	-	-	-			
R611	Line 611 Huntington Park Shuttle would be discontinued due to underutilized service and service duplication of other bus lines. This line currently is operating on Florence Av, Compton Av, Vernon Av, Leonis St, Wilcox Av, and Santa Ana St.: •Alternative bus services would be available on Florence Av (Line 111), Compton Av (Line 55), Vernon Av (Line 105), Leonis (see Line 102 information sheet), Atlantic Bl (Line 260), Seville Av and Pacific Bl (Line 60)	45	60	50	60	-	-	-	-	-	-	-	-	60	60	60	60	-	-	-	-	-	-	-	-	60	60	60	60	-	-	-	-	-	-	-	-			
R612	Line 612 South Gate Shuttle would be discontinued due to underutilized service and service duplication of other bus lines. This line is currently operating on Wilmington Av, Compton Av, 92nd St, Santa Fe Av, Florence Av, Otis St, Abbott Rd, Atlantic Av, Martin Luther King Jr. Bl, and Imperial Hwy: •Alternative bus services would be available on 103rd St (Line 117), Compton Av (Line 55), Long Beach Bl and Pacific Bl (Line 60), Florence Av (Line 111), Atlantic Av (Line 260), Martin Luther King Jr. Bl (see Line 261 information sheet), and Imperial Hwy (Line 120)	60	60	60	60	-	-	-	-	-	-	-	-	60	60	60	60	-	-	-	-	-	-	-	-	60	60	60	60	-	-	-	-	-	-	-	-			
R625	Line 625 would be discontinued due to underutilized service. Nearest alternative bus service would be Metro Line 232 on Sepulveda Bl and Beach Cities Transit Line 109 on Imperial Hwy.	20	-	20	-	-	-	-	-	-	-	-	-	-	-	-	-	-	-	-	-	-	-	-	-	-	-	-	-	-	-	-	-	-	-	-	-			
R662	New Metro Line 662 would operate two-directional service on Lake Av, Altadena Dr, Lincoln Av, Washington Bl, and Los Robles Av between Pasadena (Gold Line Del Mar and Lake Stations) and Altadena •New Lines 258 and 662 would both provide new weekend service	-	-	-	-	-	-	30	30	30	30	30	-	-	-	-	-	-	-	-	30	30	30	30	60	-	-	-	-	-	-	-	-	30	30	30	30	60	-	-
R665	Line 665 through East LA would operate all trips the full route between Olympic Bl/Soto St and Cal State University LA, instead of selected trips starting at Indiana St/Olympic Bl. This change will improve connections with Metro Lines 66, 251, and 605. More frequent Line 665 service would operate every day, including weekends.	40	40	50	40	-	-	30	30	30	30	60	-	-	60	60	60	-	-	-	30	30	30	30	60	-	-	-	60	60	-	-	-	30	30	30	30	60	-	-
R685	Line 685 would be discontinued due to underutilized service. This line currently operates between Glassell park and Glendale City College via Eagle Rock Bl and Verdugo Rd: •Line 28 will continue to serve Eagle Rock Bl •Line 90 will link Gold Line Lincoln/Cypress Station to Glendale City College (see Line 90 information sheet)	30	30	30	30	-	-	-	-	-	-	-	-	-	-	-	-	-	-	-	-	-	-	-	-	-	-	-	-	-	-	60	30	30	60	60	-	-		
R686	Line 686 would operate between Altadena (New York Dr/Allen Av) and Gold Line Del Mar Station in Pasadena and would no longer continue to Fillmore Station, avoiding overlap with new Line 260 and providing improved frequency weekdays.	40	40	40	50	-	-	30	30	30	30	-	-	40	60	60	60	-	-	-	-	-	-	-	-	40	60	60	60	-	-	40	40	40	40	-	-			
R687	Line 687 would be discontinued due to underutilized service and duplication of bus service or proximity to other bus routes. This line currently operates between Altadena and Gold Line Del Mar and Fillmore Stations in Pasadena via Los Robles Av, Colorado Bl, and Fair Oaks Av/Raymond Av. Alternative bus service would be available as follows: •Frequent New Line 660 will be available on Fair Oaks Av •Frequent New Line 662 will be available on Washington Bl, Los Robles Av, and Lake Av •Pasadena Transit will be available in the area	40	40	40	50	-	-	-	-	-	-	-	-	30	60	60	60	-	-	-	-	-	-	-	-	30	60	60	60	-	-	-	-	-	-	-	-			
R690	New Line 690 would operate between Lake View Terrace and Sylmar via San Fernando Rd., Maclay Ave., Foothill Blvd. and Terra Bella St.	-	-	-	-	-	-	30	30	30	30	30	-	-	-	-	-	-	-	-	30	30	30	30	30	-	-	-	-	-	-	-	-	30	30	30	30	30	-	-
R901	The Orange Line will continue to serve as a critical arterial service linking destinations across the San Fernando Valley, with more frequency for midday and late evening on weekdays.	5/10.	10	5/10.	10	20	40	10	10	10	10	15	30	12/30.	10/20.	10/20.	15	20	40	10	10	10	10	15	30	12/30.	10/20.	10/20.	15	20	40	10	10	10	10	15	30			
RS901		-	-	-	-	-	-	10	-	10	10	-	-	-	-	-	-	-	-	-	-	-	-	-	-	-	-	-	-	-	-	-	-	-	-	-	-			
R601		10	10	10	10	20	20	10	10	10	10	20	20	15	10	10	15	20	20	15	10	10	12	20	20	15	10	10	15	20	20	15	10	10	12	20	20			
Orange Line	There are no changes for Line 601.	-	-	-	-	-	-	5	10	5	5	15	20	-	-	-	-	-	-	10	10	10	10	15	20	-	-	-	-	-	-	10	10	10	10	15	20			
R910	The Silver Line 910 will continue operating as usual between El Monte, downtown LA and Harbor Gateway Transit Center. New Line 510 would replace Line 950 and operate between Harbor Freeway Station and San Pedro via the I-110 Freeway, remaining on I-110 and bypassing Harbor Gateway Transit Center for faster service to San Pedro.	5	30	5	30	20	60	5	10	5	10	15	30	30	30	30	40	20	60	15	15	15	20	20	30	30	30	30	40	20	60	15	15	15	20	20	30			
R950	New Line 510 would maintain convenient, same platform transfers with Silver Line 910 at Rosecrans Station, and provide connections with the future Crenshaw/LAX Line at Harbor Freeway Station.	15	30	20	40	-	-	-	-	-	-	-	-	40	30	30	40	-	-	-	-	-	-	-	-	40	30	30	40	-	-	-	-	-	-	-	-			
R510	Additional Silver Line 910 trips would operate in place of Line 950 between El Monte and Harbor Gateway Transit Center. This change would improve Silver Line 910 reliability and allow for the transition to operating new Zero Emission Buses on the Silver Line.	-	-	-	-	-	-	15	30	15	20	30	-	-	-	-	-	-	-	-	30	30	30	30	30	-	-	-	-	-	-	-	-	30	30	30	30	30	-	-
Silver Line		-	-	-	-	-	-	5	10	5	10	15	30	-	-	-	-	-	-	15	15	15	20	20	30	-	-	-	-	-	-	15	15	15	20	20	30			

TABLE OF CONTENTS

LIST OF TABLES AND FIGURES 3

EXECUTIVE SUMMARY 5

SECTION 1: INTRODUCTION, PURPOSE & BACKGROUND 6

SECTION 2: DESIGNING A WORLD CLASS BUS SYSTEM 10

SECTION 3: SERVICE DESIGN GUIDELINES 13

 3.1 Service Design Concepts 13

 3.2 Service Standards 16

 3.3 Metro Bus Routing Guidelines 19

 3.4 Vehicle Assignment 22

 3.5 Charter Service 23

 3.6 Special Event Service 24

 3.7 Service Transfer Guideline 24

 3.8 Alternative Service Delivery Options 26

SECTION 4: CUSTOMER INFORMATION AND AMENITIES 27

 4.1 Customer Information 27

 4.2 Customer Amenities 28

 4.3 Rail Stations and Major Off-Street Bus Facilities 29

 4.4 Bus Stop Amenities 30

 4.5 Bus Stop/Station Location, Design and Guidelines 31

SECTION 5: SERVICE PERFORMANCE EVALUATION 38

 5.1 Route Performance Index 38

 5.2 Customer Experience 39

 5.3 Service Evaluation Process 40

SECTION 6: SERVICE CHANGE PROCESS 42

 6.1 Service Change Programs 44

 6.2 Title VI and Metro’s Equity Platform 44

 6.3 Title VI Equity Analysis 46

 6.4 Public Outreach 49

 6.5 Public Hearing Process 51

 6.6 Implementing Minor Changes on an Interim Basis 51

APPENDICES..... 52

 APPENDIX A: Metro Line Identification..... 53

 APPENDIX B: Los Angeles County Local Fixed and Demand Response Route Transit
 Operators..... 57

LIST OF TABLES AND FIGURES

SECTION 1: INTRODUCTION, PURPOSE & BACKGROUND

Table 1.1 Metro Bus Service Types and Features.....6
Table 1.2 Service Type Determination.....7

SECTION 3: SERVICE DESIGN GUIDELINES

Table 3.1 Service Design Concepts.....16
Table 3.2 Maximum Headway by Service Type.....16
Table 3.3 Passenger Loading Standards by Vehicle Type.....17
Table 3.4 Maximum Avg. Stop/Station Spacing.....18

Figure 3.1 40-foot bus turning radius.....20
Figure 3.2 45-foot bus turning radius.....21
Figure 3.3 Articulated 60-foot bus turning radius21

SECTION 4: CUSTOMER INFORMATION AND AMENITIES

Table 4.1 Passenger Amenities.....30
Table 4.2 Comparative Analysis of Bus Stop Locations.....33

Figure 4.1 General Standard Bus Stop/Zone Attributes.....35
Figure 4.2 Typical Near-Side Bus Stop.....36
Figure 4.3 Typical Far-Side Bus Stop.....37
Figure 4.4 Typical Mid-Block Bus Stop.....38

SECTION 6: SERVICE CHANGE PROCESS

Table 6.1 Service Change Timeline.....44
Table 6.2 Timeline for Public Notification Activities.....51

Figure 6.1 Metro Service Council Areas.....43
Figure 6.2 Service Change Process.....46

This page intentionally left blank.

EXECUTIVE SUMMARY

Los Angeles County Metropolitan Transportation Authority (Metro) serves as transportation planner and coordinator, designer, builder and operator for Los Angeles County. More than 8.6 million people live, work, and play within its 1,469-square-mile service area.¹

In 2018, the Board adopted Metro Vision 2028 as the agency's strategic plan. The plan outlines five goals to guide the development of transportation in LA County. Metro must ensure that: our customers feel safe when riding, that they do so in clean equipment, service is reliable and on-time, and our staff provides service in a courteous manner.

Goal 1: Provide high-quality mobility options that enable people to spend less time traveling

Goal 2: Deliver outstanding trip experiences for all users of the transportation system

Goal 3: Enhance communities and lives through mobility and access to opportunity

Goal 4: Transform LA County through regional collaboration and national leadership

Goal 5: Provide responsive, accountable, and trustworthy governance within the Metro organization

Metro's Transit Service Policy (TSP) establishes criteria and guidelines to ensure that the transit system is developed and managed consistent with policy guidance approved by the Metro Board of Directors, including a formal process for evaluating services, service design guidelines, and a process for implementing service changes.

¹ FY19 National Transit Database

SECTION 1: INTRODUCTION, PURPOSE & BACKGROUND

Metro operates a comprehensive bus and rail network that complements Metro Rail and municipal operator services. Determining the most appropriate transit service in a corridor depends on several factors such as level of demand, resource availability, site or corridor characteristics, environmental considerations, and community acceptance. The characteristics that determine which type of service is most appropriate are summarized in Table 1.1.

Table 1.1 *Service Type Determination²*

Service Type	Corridor	Optimal Characteristics
Heavy Rail (Subway)	Operate 100% within an exclusive right of way.	- 2,500 boardings per route mile or more than 50,000 boardings per day. - Ability to construct a fully grade-separated facility.
Light Rail	Operate in mixed flow traffic or an exclusive right of way.	- 1,000 boardings per route mile or more than 25,000 boardings per day. - Ability to construct a guideway within or adjacent to the corridor.
Commuter Routes	Operate in mixed flow traffic in along either an HOV or HOT Lane and may operate a segment of their route on local streets.	300 or more boardings during peak-hour and in peak direction of travel.
BRT and Rapid	Operated using 40', 45' or 60' buses. - Metro G Line (Orange) (BRT) operates on a fixed guideway. - Metro Rapid and Hybrid Lines operate in exclusive bus lanes or mixed flow traffic on local streets with signal priority.	- 300 or more boardings during peak-hour and in peak direction of travel. - Daily average of more than 500 boardings per route mile or more than 10,000 daily boardings. - Ability to implement operating speed improvements in the corridor.
Core, Convenience, Connectivity and Community Routes	Operate in mixed flow traffic on local streets by 32', 40', 45', or 60' buses.	- The median bus route carries about 4,500 daily boardings. - Core and Convenience services are expected to carry more than the daily median, while Connectivity and Community are anticipated to carry less.

Metro Bus

Metro currently operates 165 bus routes, of which 18 routes are contracted out. Metro serves nearly 14,000 bus stops, including station stops on the G Line (Orange) and J Line (Silver) BRT systems. On weekdays, Metro operates a fleet of over 2,300 buses. Metro's bus operations consist of both directly operated and contract operated services. Metro operates the largest

²Capacity limits adapted from TCRP, Research Results Digest, November 1999—Number 35, Highlight of Large Transit Capacity and Quality of Service Manual, Figure 1 Achievable Capacity (Peak direction passengers/hour)

share of all bus services provided in the region. Municipal and Local Return operators provide additional public bus and paratransit services in areas of the region where Metro provides limited service or no service at all.

Metro classifies its bus services into tiers stratified by the frequency of service. The tiers are assigned to individual routes in accordance with demand and propensity for future growth. Table 1.2 describes the features of each of Metro’s bus service types. Tier definitions are:

- **Core (Tier 1):** weekday all day headways of 7.5 minutes or better
- **Convenience (Tier 2):** 7.5 to 10 minutes
- **Connectivity (Tier 3):** 10 to 15 minutes
- **Community (Tier 4):** 15 to 30+ minutes
- **Commuter (Tier 5):** Varies

Table 1.2 *Metro Bus Service Types and Features*

Feature	Bus Service Type			
	BRT	Rapid	Commuter	Core, Convenience, Connectivity, Community
Right of Way	Dedicated right-of-way	Major arterials	Major arterials and freeways.	Major arterials and local streets
Minimum Average Stop Spacing	1.25 miles	0.75 mile	1.25 miles	0.2 - 0.30 mile
Target Travel Market	Inter-community	Inter-community	Inter-community, regional	Inter-community, neighborhood
Vehicle Type	45/60-foot buses	40/45/60-foot buses	40-foot bus	40/45/60-foot buses
Communities Served	Multiple	Multiple	Multiple	Multiple
Signal Priority	Yes	Yes	No	
Fare Collection	On board /pre-pay	On Board	On Board	On Board
Passenger Amenities	Shelters and stations	Shelters and stations	Shelters and stations	Benches and shelters
Real-time Passenger Info	Yes	Yes	Yes	

Note: Proposed stop spacing standards provide for the average stop spacing in miles by type of service and spacing should fall within 0.1 mile of the specified average at least 90% of the time.

Metro Bus Rapid Transit (BRT)

To support BRT, Metro incorporates a series of design features to reduce delays, increase reliability and improve customer comfort. Metro operates two high-capacity vehicle types: 45-foot buses with 46 seats and articulated 60-foot buses with 57 seats. Ideally, high-capacity vehicles should primarily be operated on high-volume trunk service routes with more than

10,000 total daily boardings. Metro BRT services operate on an exclusive right-of-way, major arterials, or in HOV/HOT lanes.

Metro operates two such routes: the G Line (Orange) which operates on its own exclusive right-of-way, and the J Line (Silver) which operates on the I-10 and I-110 ExpressLanes (freeway toll lanes) as well as surface streets through downtown. These are considered Tier 1 services. BRT services charge a premium fare.

- **Dedicated Bus Lanes:** A bus lane is an exclusive lane used by transit on urban streets along a roadway through widening or dedication of one or more existing general traffic or parking lanes for transit use. These lanes can be designated for transit use during peak periods only or all day. Bus lanes typically allow use by general traffic for right turn movements, bicycles, parking, and local access to and from driveway, and are most effective in those areas where there are very high bus or customer volumes and where operational efficiencies can be achieved. Bus lanes should be a minimum of 17 feet wide. This right of way provides fewer traffic conflicts and obstructions and reduces delays and travel time. Metro is currently studying the feasibility of adding bus lanes on several major corridors to further improve travel times.
- **High-Capacity Vehicles:** State-of-the-art high-capacity vehicles are used to meet high demand and provide greater customer comfort.
- **Transit-Signal Priority:** An operational strategy that facilitates the movements of in-service transit vehicles through signalized intersections to improve transit performance by extending the green phase or shortening the red phase of traffic signals.
- **Bus Stations and Shelters:** Stations and shelters provide customers with enhanced comfort and safety.
- **Streetscape:** Streetscape and other design features such as landscaping, pedestrian count-down signals, bicycle racks, and well-designed crosswalks make it easier for pedestrians and bicyclists to access the stations.
- **Improved Fare Collection:** For faster service and convenience, major stations have ticket vending machines (TVMs) which allow customer s to preload their TAP cards.
- **Park & Ride Facilities:** Provided in close proximity to major stops and stations. Adjacent development and joint use parking are encouraged.
- **Advanced Transportation Management Systems:** ATMS provide an array of technologies to improve service reliability and customer travel.

The advantage of their deployment is the opportunity to reduce vehicle requirements and service hours; however, deployment should not increase service intervals to the point where service quality is degraded. For this reason, bus lines with a peak headway of five minutes or less are ideal candidates for this type of vehicle. In evaluating services for higher capacity vehicles, other factors must be considered including facility compatibility, street design, and potential impacts to services where schedules have been interlined.

Metro Rail

Metro operates two heavy and four light rail lines serving a total of 96 stations across approximately 101 route miles, with a fleet of 406 heavy and light rail cars.

Metro Rail operates in heavily congested travel corridors and provides connections to key multi-modal transportation hubs. Metro operates two types of rail service to better match the transit mode with specific customer demand and needs. Metro Rail is high-capacity rapid transit service operating along a dedicated right-of-way, serving full-scale transit stations, and powered by electricity. The rail system supports public transportation in the greater Los Angeles region, linking many key multi-modal transportation centers and destinations together.

Rail service operates in high-demand travel corridors and is offered in two forms – heavy rail and light rail. Metro’s heavy rail is the subway system served by the B and D Lines (Red, Purple) powered by a third rail. Metro’s four light rail lines – A (Blue), C (Green), L (Gold) and E (Expo) – are powered by overhead catenary wires, generally use shorter trains, and operate at slower speeds than heavy rail. Unlike heavy rail, light rail lines run along a right-of-way ranging from complete grade separation to at-grade in mixed flow traffic.

Transit Service Policy (TSP)

The TSP was originally adopted in 1986 and is reviewed on an annual basis. This document sets forth the policies, principles, and service guidelines that are used by Metro staff in the design or modification of the bus network to better serve customers and make more beneficial use of available operating resources. This document outlines the service change process that provides the quantitative tools to evaluate the system, identifies opportunities for service improvements, and ensures the regional transit system is adjusted according to the service goals and objectives approved by the Metro Board.

The TSP is updated as needed to better reflect agency goals and objectives, major initiatives, and changes in local, state, and federal regulations and funding.

This document updates the most recent version adopted by the Board in FY2016.

SECTION 2: DESIGNING A WORLD CLASS BUS SYSTEM

In 2018, the Board adopted Metro Vision 2028 as the agency's strategic plan. The plan outlines five goals to guide the development of transportation in LA County. The NextGen Bus Study was also initiated in 2018 to reimagine the Metro bus network to be more relevant, reflective of, and attractive to the diverse customer needs within Los Angeles County. NextGen addresses **Goal #1: Provide high quality mobility options that enable people to spend less time traveling.** The study also encompasses two sub-goals: 1) Target infrastructure and service investments towards those with the greatest mobility needs; and 2) Invest in a world class bus system that is reliable, convenient, safe, and attractive to more users for more trips.

In addition to the strategic plan, the Board adopted Motion 38.1 (June 2018), endorsing travel speed, service frequency, and system reliability as the highest priority service design objectives for the NextGen Bus Study. Finally, regardless of the level of resources expended on the bus network, optimizing system performance should always be an objective in network design to maximize benefit to the public.

These goals and objectives drive the development of the NextGen Service Plan, including routing, stop spacing, frequency, span of service, and coordination with municipal operators. In addition, a set of performance measures have been defined below to ensure the bus network continues to evolve consistent with the goals and objectives defined by the Board.

NextGen Service Plan

Metro Vision 2028 envisions building a World Class Transportation System in which a World Class Bus System is a cornerstone to its success. Building a World Class Bus System requires improving the attractiveness and competitiveness of the bus network. Attractiveness includes addressing issues such as safety and security, cleanliness, comfort, real time arrival information, easy fare payment, wayfinding and signage, and first/last mile access. Competitiveness requires developing a bus network that minimizes the overall travel time to complete a trip compared to the driving alternative. This travel time considers directness of route, access to the bus stop, waiting time, and onboard travel time.

NextGen's primary purpose is to improve the competitiveness of the bus network. However, through this process, improvements to certain aspects of attractiveness can also be achieved. The following outlines a strategy for how NextGen will set the foundation for building a World Class Bus System.

Step 1: Reconnect Scenario: Metro currently provides roughly 7 million revenue service hours (RSH) of bus service per year. The first step in creating a World Class Bus System is to redesign the routes and schedules to attract trips where and when there is the greatest market potential. The lessons learned in Phase 1 of the bus study present a path forward for reinventing the bus network:

- **85% of LA County residents have used transit at least once in the past year, THEREFORE, we should attempt to maintain coverage throughout the County by minimizing discontinued segments.**

- **Fast/Frequent/reliable service is key**; THEREFORE, we need to create a competitive transit network that reduces overall travel time by optimizing all components of the trip, including walking, waiting, and riding.
- **Metro’s current system is not always competitive to get people where they want to go**, THEREFORE routing should be adjusted to reflect the key origins and destinations identified in the cell phone location data.
- **The greatest opportunity to grow ridership is between midday & evening when many trips are short distance**, THEREFORE service levels should be improved for midday, evenings and weekends.
- **Need to integrate Metro’s Equity Framework into the planning process**, THEREFORE service improvements should be prioritized for equity-focused areas.

These lessons learned to “reconnect” routes and schedules with where and when people travel today were incorporated into the Service Design Guidelines outlined in Section 3 to develop the NextGen Reconnect service plan. Reconnect is estimated to increase ridership by 5% with no additional increase in revenue service hours.

Step 2: Transit First Scenario: Once the bus network is reestablished to reflect the travel patterns of today, the next step in building a World Class Bus System is to: 1) invest in speed and reliability infrastructure, 2) create safe and comfortable waiting environments, 3) improve the boarding and riding experience, and 4) establish facilities to optimize layovers. These capital improvements create a more competitive and attractive bus network while saving resources to be reinvested into more service.

- **Speed and Reliability Improvements** – As bus system speeds continue to decline, Metro must allocate an additional \$10 million cumulatively every year to provide the same amount of service. Not only does this reduce the opportunity to increase service, it degrades our competitiveness and attractiveness. Therefore, investing to improve the speed and reliability of the bus system is critical to the success of NextGen. Some improvements can be implemented within METRO’s control, such as optimizing stop spacing, all door boarding, and headway-based service management. However, other improvements can only be implemented through collaboration with local jurisdictions, including transit priorities, bus bulb outs, and bus only lanes. Under the Transit First scenario, \$750 million in capital improvements are proposed to support speed and reliability improvements for the regional bus network. This investment is anticipated to save 25%-34% in system speed if fully implemented.
- **Customer Wait Environment** – Through the significant public outreach conducted in Phase 1, as well as other Metro efforts such as the How Women Travel Study, we learned that an uncomfortable and unsecured wait environment is a significant barrier for customers in using the bus network. This is particularly concerning for women who account for over half of our customers and often travel with young children. Metro completed the Transfer Design Guideline in March 2018. Under the Transit First scenario, we plan to begin implementing the recommendations from this policy document at our busiest wait and transfer locations. This investment is anticipated to cost \$150 million

and address several of the safety and comfort issues identified in the NextGen outreach and How Women Travel Study.

- **Boarding and Riding Experience** – Metro has implemented All Door Boarding on several lines, including G Line (Orange), J Line (Silver), Line 720 (Wilshire), and Line 754 (Vermont). Experience on the J Line (Silver) showed that dwell times were reduced by 15% on average, on time performance improved, cash payment declined with more TAP penetration, and significant customer and operator satisfaction. Other strategies to improve boarding and on board experience include level boarding at key stops and improved on board information. These improvements are estimated at \$100 million systemwide.
- **Layover Optimization** – Due to limited curb space, many routes are extended purely to access a layover location. These unnecessary route extensions cost several million dollars in operating cost per year with little to no benefit to the customer. By investing in off street layover terminals to optimize layover locations, we can reallocate wasted resources and reallocate it to more productive use. In addition, these locations would provide facilities for better regional mobility coordination, a better wait and rest environment for customers and operators, improve bus service reliability, and opportunities for new en route Zero Emissions Bus (ZEB) charging infrastructure.

This \$1 billion capital program is expected to achieve resource savings by generating more revenue service miles/trips within the same revenue service hours. These savings would be reinvested into Transit First service improvements, including:

- Ensure that all bus lines operate seven days per week;
- Ensure no wider than 30 minute headways on any line between 6:00 am and 7:00 pm;
- Expand owl (overnight) service on an additional eight lines;
- Increase weekday midday and evening service levels;
- Increase weekday evening service levels.

Investing “one time” capital dollars into transit supportive infrastructure would increase the attractiveness and competitiveness of the bus network, while freeing resources to reinvest into service enhancements. Under the Transit First scenario, these benefits are expected to generate a 15-20% increase in ridership (10-15% over Reconnect) without additional increases in revenue service hours.

Step 3: Future Funding Scenario: Should future funding be secured through efforts such as de-congestion pricing, additional resources can be added to the Transit First network. However, without disincentives for driving, there will be diminishing returns on benefits since most customers would already have been served within the Transit First Scenario. Therefore a 34% increase in revenue service hours would only be expected to yield a 10% increase in ridership over Transit First.

SECTION 3: SERVICE DESIGN GUIDELINES

Key Principles of Network Design

Three key elements are taken into consideration during the Network Development Process to identify when and where transit can be successful.

- **Transit Propensity** – Areas where the propensity to use transit is the greatest embody three main characteristics. First, there is a significantly large population of transit market segments, including people who rely on transit for most of their travel, commuters and students who use transit for work and school trips, and discretionary customers who choose transit for some or all their trips. Second, is the intensity of travel demand to and from areas based on population and employment densities, retail and entertainment, colleges and universities, and other trip generators. A pedestrian oriented street environment is also critical, including safe and well lighted pathways, sidewalks and curb-cuts, grid street network, and level topography.
- **Existing Service Performance** – It is important to identify the most productive segments of the existing bus network which articulates current transit demand. These corridors and routes should be optimized through the network development process, and lessons learned should be applied to other areas with similar demand and service characteristics.
- **Service Environment** - A transit-oriented service environment is also critical to the success of transit, including the pedestrian orientation of the streets and land use, barriers to other modes such as limited and costly parking supply, and transit supportive infrastructure including bus only lanes and transit priorities.

Once these key elements are taken into consideration in the Network Development Process, this transit orientation can then be translated into design considerations, including elements explained in the following sub-sections.

3.1 Service Design Concepts

Service design concepts, developed as part of the NextGen Bus Study, are guidelines established based on the feedback received through the study's stakeholder and public outreach sessions. Network characteristics most important to the public include:

- Faster service
- Frequent service throughout the day
- More reliable service
- Better network connectivity
- Accessibility to key destinations
- Improved security

Based on these service themes, the following service design concepts will guide the design of the Metro bus network:

Hybrid Local/Rapid Stop Spacing – Currently stop spacing is determined by route classification. For example, local lines are planned with $\frac{1}{4}$ mile stop spacing while Rapid lines have $\frac{3}{4}$ to 1 mile stop spacing. As a result, customers travelling on local lines go slower between communities but have closer access to origins and destinations. Conversely, Rapid customers

travel faster along a corridor, but may be picked up or dropped off much further from their origin or destination. In addition, resources are split between the local and Rapid lines resulting in wider headways for each service. Therefore, overall end to end travel time including walking/rolling to the stop, waiting for the bus and finally the in-vehicle run time may result in longer travel times on the Rapid, especially for shorter distance trips.

Consolidating local and Rapid resources along a corridor will provide much better headways, and customizing stop spacing along the corridor based on changing land use densities along a corridor results in shorter wait times, faster on board travel times compared to the local, and shorter walk/roll compared to Rapid service. In addition, this standardizes the frequency along the entire corridor, vs inconsistent frequencies between local and Rapid services that have different speeds.

Shorter Route Lengths and Subarea Transit Hubs – The cell phone location based data indicates that almost half of all travel in Los Angeles County are within 1 to 5 miles. In addition, the origin-destination travel patterns indicate that many people travel locally and not necessarily regionally across the region. Creating shorter route lengths will improve schedule reliability. Being able to tie the lines to subarea transit hubs will improve network efficiencies and provide a safer and more convenient location for transfers.

Municipal Operator Coordination – Metro serves as LA County’s regional coordinator of transit services. Improved coordination between all operators and modes is vital to establishing an integrated regional transit network. Metro operates within a hierarchy of services, in which Metrolink provides the region’s commuter rail to serve high volume, longer distance trips. Metro Rail, Metro BRT [G Line (Orange) and J Line (Silver)], and Metro Bus serves as the backbone of the urban transit network, which is augmented by municipal operators. Municipal and local return operators complement the system with community and shuttle buses that serve specific neighborhood needs.

Roughly one third of transit service in LA County is provided by municipal bus operators and Metrolink. Their coverage is especially strong in Santa Monica, South Bay, Gateway Cities, and eastern San Gabriel Valley. Therefore, it is imperative that Metro bus service is closely coordinated with municipal transit service. Given that several of the municipal operators are currently undergoing their own system redesigns, there is an opportunity to work together to develop service change ideas between Metro and municipal services to improve overall coordination for customers.

MicroTransit and Other On-Demand Services – Some areas of the County are difficult to serve with fixed route transit due to terrain, narrow streets, and dispersed lower density destinations. In addition, travel activity in some areas are low during certain times of day or days of week. Metro is currently piloting Mobility on Demand and will be implementing a pilot program for MicroTransit. These service modes may be more appropriate for areas and times of day where fixed route cannot be competitive and will be considered for application in lieu of fixed route if warranted.

Standardize Frequencies by Service Tiers – Currently, schedules are written based on the Board-adopted load standard for frequent services (15 min or better) and based on policy for infrequent services (wider than 15 min). To ensure the core network has consistent frequencies and span of service, corridors will be categorized into tiers based on transit propensity, current ridership, and overall travel demand. Each tier will be assigned a frequency designation (e.g. 10 min peak/12 min base) to ensure that all services within the tier provide consistent service levels for ease of transfer along the network. If a line requires better frequencies than the tier designation, it will be set based on the Board-adopted load standard.

Routing to Reflect Current Travel Patterns and Transit Propensity – Currently corridors are being evaluated by segments. Based on the origin – destination travel patterns identified using the cell phone location based data as well as regional TAP data, the segments will be connected together to create lines. Better aligning the routing with travel patterns is expected to reduce the number of transfers required to make a trip and increase the distance travelable and access to opportunities along the network within 15 min, 30 min, etc. While resources will be focused in areas with high transit propensity, there will be a concerted effort to maintain service in areas of low demand but with the greatest mobility needs.

Table 3.1 *Service Design Concepts*

	Faster service	Frequent service throughout the day	More reliable service	Better network connectivity	Access to key destinations	Improved security
Routing to reflect current travel patterns and transit propensity				X	X	X
Standardize Frequencies by Service Tiers	X	X				
Subarea transit hubs				X		X
Shorter route lengths			X			
Optimize stop spacing	X		X			
Municipal operator coordination				X	X	
MicroTransit and other on- demand		X			X	
Transit supportive infrastructure	X		X			X

Transit Supportive Infrastructure – The service design will identify transit supportive infrastructure that either improves overall travel time and reliability or reduces inefficiencies in the network. Speed and reliability improvements include bus only lanes, queue jumpers, bus bulb outs, signal retiming, All Door Boarding, fare payment technology, etc. improves the

attractiveness and competitiveness of transit while reducing revenue hours that can be reapplied to better use. Infrastructure that optimizes terminals and layover locations, reduce out of direction movements, and improves transfer movements will reduce non-revenue miles and hours that can be reallocated to revenue service.

Table 3.1 illustrates how each service concept will address the various themes expressed by the public and stakeholders.

3.2 Service Standards

Service standards are established to ensure that service levels are maintained based on board adopted standards.

Headways

The headway standard provides for the maximum scheduled gap (in minutes) between trips in the peak direction of travel at the maximum load point of a line by time of day, and it should not be exceeded for at least 90% of all hourly periods as summarized in Table 3.2.

Table 3.2 *Maximum Headway by Service Type*

Service Type	Peak	Off-Peak
Heavy Rail	10	20
Light Rail	12	20
Core Network	7.5	7.5
Convenience Network	10	10
Connectivity Network	15	15
Community Network	30	30
Commuter Network	varies	varies
Micro-Transit	varies	varies

Passenger Loads

Passenger loading standards have been developed to ensure there is sufficient service capacity on Metro Bus and Rail service. The loading standard for bus is based on the maximum average ratio of customer s to available seating per vehicle size (i.e. 40-foot, 45-foot, and 60-foot buses). The loading standard for rail is based on the maximum average ratio of customer s per seat by service type (i.e. Heavy Rail and Light Rail). Current loading standards are shown in Table 3.3.

- **Bus Passenger Loading Standard** expresses the maximum average ratio of customer s to vehicle size and frequency by direction for a one-hour period that should not be exceeded for at least 95% of all hourly periods. This TSP sets the current loading standard for Metro bus to 1.3 as recommended by the 2016 APTA Peer Review Committee. Vehicles used for MicroTransit or Mobility-on-Demand will have a load standard of 1.0.

- **Rail Passenger Loading Standard** expresses the maximum average ratio of customers to seats by service type and by direction for one-hour period by time of day and should not be exceeded for at least 95% of all hourly periods.

Table 3.3 *Passenger Loading Standards by Vehicle Type*

Service Type	Seats per Vehicle	Passengers per Seat	Maximum Passengers Onboard
Heavy Rail	54	2.30	124
Light rail	76	1.75	133
Bus – 40 foot	38	1.30	49
Bus – 45 foot	46	1.30	60
Bus – 60 foot	57	1.30	74

Wheelchair Boardings and Pass ups.

Ideally, in a floating 6-month period, regular operating bus service will average of no more 6% pass-ups of customers who use wheelchairs or other mobility devices. Should the average increase to over the threshold of 6%, Service Planning will adjust service to better serve the ridership patterns of the route in such a way so as to minimize pass-ups.

Network Route Spacing

Network Route Spacing refers to the average distance between two or more parallel bus and/or rail lines. It is generally accepted that customers are willing to walk up to 0.25 mile to a bus stop. Generally, bus routes operating parallel to each other in an urban area should be spaced 0.5 mile apart from one another and bus routes operating parallel to rail should be spaced a 0.5 mile apart on either side of a rail route. Bus routes operating parallel in a suburban area should be spaced no more than one mile apart from each other, and bus routes operating in low density or underdeveloped areas should be operated where needed in a cost-effective manner. Where possible, alternate delivery methods should be considered.

Bus Stop/Station Spacing

Stop/Station spacing refers to the average distance between consecutive stops/stations along an entire bus/rail route. The standard is expressed as the maximum average stop/station spacing in miles by type of service and is not to be exceeded by at least 90% of all routes operated. Stop/Station spacing is established based on the goals and guidelines each service type is designed to achieve as discussed below. Metro’s maximum average stop/station spacing by mode is summarized in Table 4.3.

- **Heavy/Light Rail Line** station spacing is greater than bus stop/station spacing to achieve the highest speed. Rail station location is determined during the design phase. Ideal average rail station spacing should be no greater than 1.50 miles.
- **BRT and Commuter Bus Routes** achieve the highest bus speeds through even greater stop spacing than Rapid, Core, Convenience, Connectivity, and Community routes. To ensure these services provide access to major activity centers and transfer points, average stop/station spacing should be no greater than 1.25 miles, though there may be exceptions due to geography or existing facility design. See Table 3.4 for further details.

- **Core, Convenience, Connectivity and Community Bus Routes** primarily operate on city streets and secondary streets respectively. These route types are designed to provide service closer to a customer’s destination and reduce walking times. Therefore, average stop spacing should be no greater than 0.25 mile for convenient walk access.

Decisions regarding bus stop spacing and location call for analysis of ridership density, customer service requirements, the safety of customer s, operators, equipment, the service type provided, interaction of stopped buses with general traffic flow. Stops should be closer together in major commercial districts and farther apart in outlying areas.

Table 3.4 *Maximum Avg. Stop/Station Spacing*

Service Type	Stop/Station Spacing
Heavy Rail	1.50
Light Rail	1.50
BRT	1.25
Rapid	0.75
Commuter	1.25
Core, Convenience, Connectivity, Community	0.30

3.2 Bus/Rail Interface Planning

As the Metro Rail system expands, adjustments are made to the bus system to improve access to rail stations, take advantage of new transfer facilities, and reduce bus and rail service duplication. The following guidelines provide direction to routing and scheduling changes that will be necessary as the Metro Rail system is expanded:

Discontinuation of Parallel Limited and Express Service

Competing Commuter services that parallel the rail corridor will be discontinued when duplication exists.

Bus Route Deviation

Bus routes that run parallel to a rail line may be diverted to a station when:

- Walk time from the nearest station is greater than 3 minutes;
- Diversion time in one direction is 5 minutes or less; and
- Net travel time benefit for connecting customer s exceeds increased travel for through travel.

Intersecting bus lines or ones that travel in a perpendicular direction to a rail line will be diverted to serve the closest rail station when:

- Diversion time in one direction is 5 minutes or less
- Net travel time benefit for connections and through travel

Extend Terminating Lines

Bus routes that end within one mile of a rail station will be extended to terminate at the station. Routes that terminate at distances greater than one mile may be extended if the rerouting will create a valuable link to the rail system or will result in a reduction in travel time for a significant number of customers.

New Bus Routes

New rail feeder service will be considered as part of the service change process if a need is demonstrated and if funding is available.

Scheduling Rail/Bus Interface

Bus arrival and departure times should be governed by the rail arrival and departure times when predominant movement is from bus to rail. Bus routes with frequencies of 20 minutes or greater ending at a rail station should be scheduled to arrive 5 minutes before the rail departure time. When the predominant movement is from rail to bus, terminal buses should be scheduled to depart 5 minutes after the scheduled rail arrival time.

3.3 Metro Bus Routing Guidelines

An easy-to-understand-and-use transit system relies on simple network and route design. Consolidating duplicative services on the same or parallel corridors within a quarter-mile to a half-mile distance provides an opportunity to simplify the network for ease of use and reduce unused capacity. This concept requires better coordination of schedules and transfer points and will result in an easier-to-use and more convenient system while reducing wait time and overall travel time.

Metro's directly operated service primarily operates three types of buses: a standard 40-foot bus, a 45-foot bus, and a 60-foot "articulated" bus. To ensure that buses can adequately navigate route alignments and serve bus stops, Metro established the following standards:

- **Transit Centers /Bus Terminals**
 - Layover zones should be designed to accommodate various sizes of buses.
 - Re-striping of layover zones should be completed as needed based on the needs of the service and bus sizes scheduled.
 - Routes should be scheduled so that the amount of layover space needed is available. Layover zones should be placed as close as possible to the route terminal. Where not accommodated by the design, the added operating cost to serve the location will be computed and made part of the decision-making process for bus/rail interface.
- **Minimum turning radius clearance** required for each type size bus movement
 - 50 feet for 40-foot buses (Figure 3.1)
 - 47.5 feet for 45-foot buses (Figure 3.3)
 - 44 feet for 60-foot articulated buses (Figure 3.2)

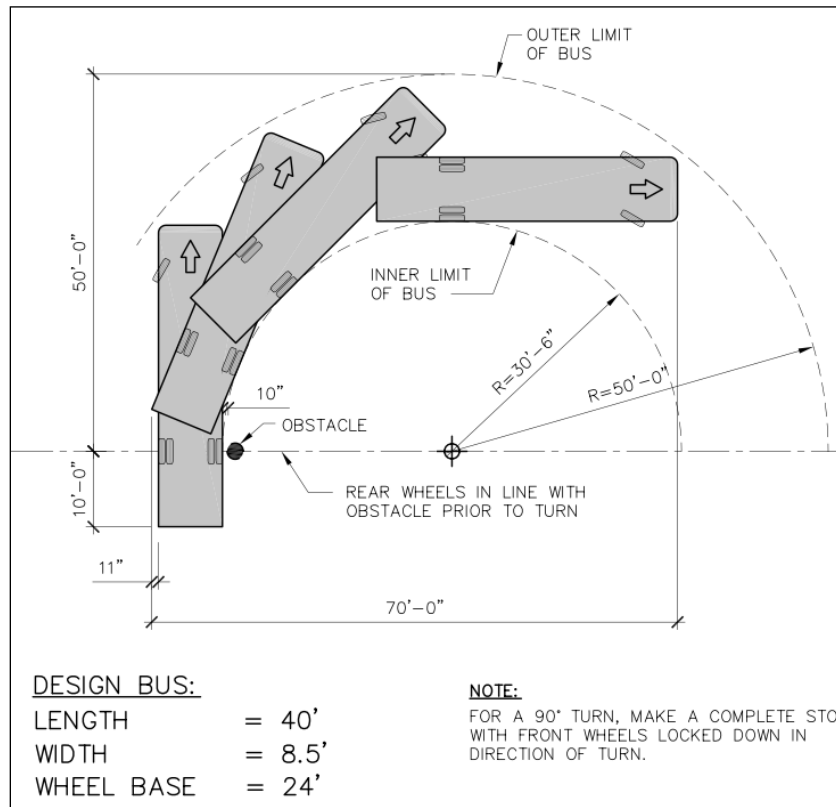

Figure 3.1 40-foot bus turning radius

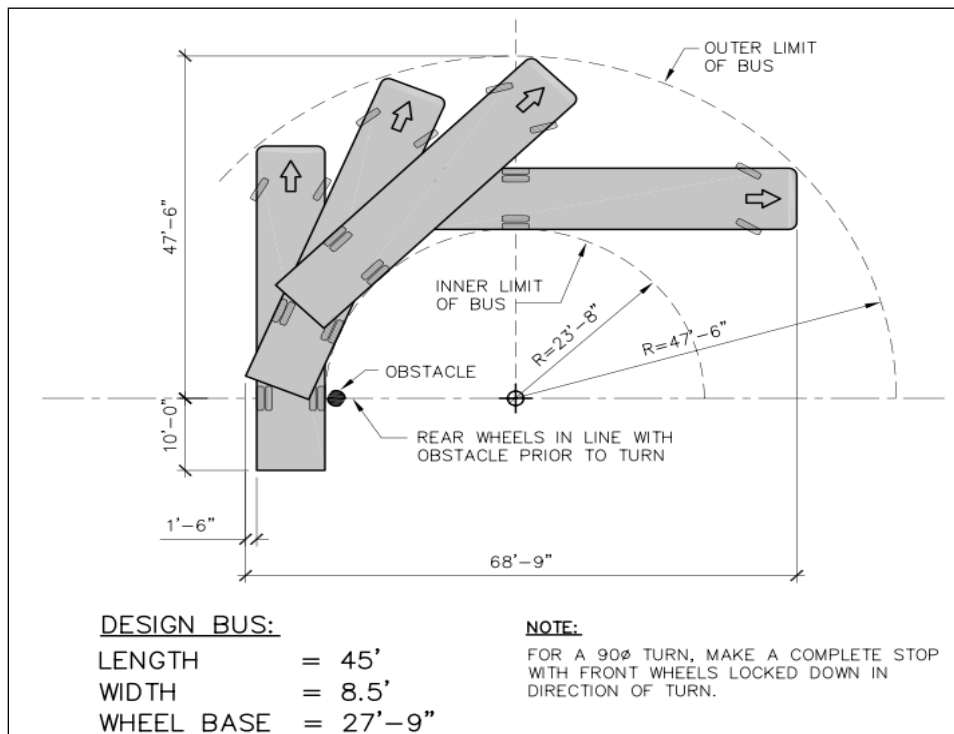

Figure 3.2 45-foot bus turning radius

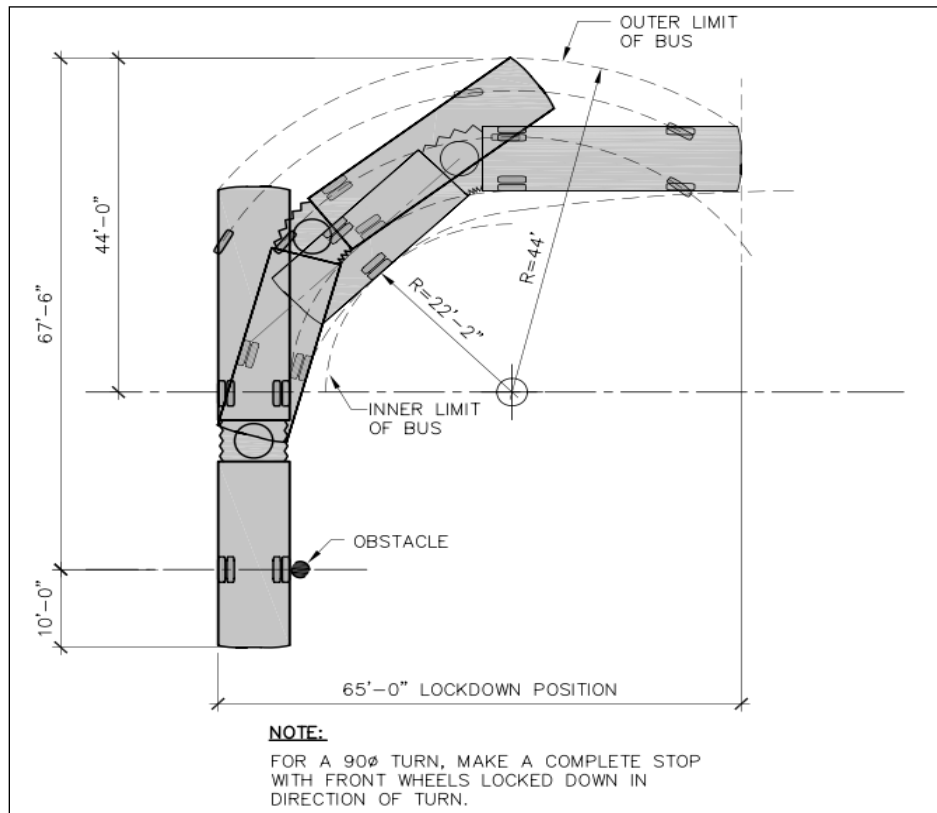

Figure 3.3 Articulated 60-foot bus turning radius

- Desired street lane widths for bus operations should be 12 feet or more.
- **Optimal Bus Stop Curb Lengths and Zone**
40-foot buses should at minimum:
 - Far-side – 90 feet
 - Near-side – 100 feet
 - Mid-block – 150 feet

For two 40-foot buses servicing a stop simultaneously, add 50 feet. Additional bus stop curb length may be needed for 45-foot buses.

60-foot bus should at a minimum:

 - Far-side and mid-block – 120 feet
 - Near-side – 170 feet

For two 60-foot buses servicing a stop simultaneously, add 70 feet.
- **Bus Layover Zone** general space requirements based on frequency between scheduled trips:
 - One space – 15 minutes
 - Two spaces – 12 minutes
 - Four spaces – 6 minutes

3.4 Vehicle Assignment

Metro's goal is to ensure a consistent basis for assigning vehicles to facilities to meet operating needs at a minimal cost and improve quality of service. This policy ensures that operating needs are met at a minimal cost and improve quality of service.

Metro's transit system consists of light rail, heavy rail, and bus operations.³ On any given weekday, Metro serves approximately 925,000 bus boardings and 297,000 rail boardings.⁴

- **Buses:** Buses will be assigned to individual facilities based on vehicle size requirements for lines supported by each facility.
- **Light Rail:** Light Rail cars will be assigned to individual lines based on compatibility of vehicle controllers with each line's signal system. Ideally, the number of vehicle types/manufacturers will be kept to no more than two at any facility to minimize parts storage and maximize maintenance expertise.
- **Heavy Rail:** Assignment policy is not applicable to Heavy Rail. The Metro B Line (Red) and D Line (Purple) operate out of the same division and both are operated by the same vehicle type.

3.5 School Trippers

School trippers are extra service operated to protect against overcrowding on bus routes serving schools. Metro's policy on school trippers is based on FTA regulations (49 CFR Part 605). These regulations are directed at protecting the private sector against unfair competition and ensuring that FTA funding is focused on providing services that meet the needs of the public. School tripper service may be operated if it meets the following criteria:

- There is sufficient demand to warrant the operation of a tripper;
- There are sufficient resources to operate a tripper;
- The school tripper will not result in a significant increase in travel time for regular customers; and
- The school tripper is operated as part of the regularly-scheduled public transportation service.

School tripper service must meet the following requirements:

- All school trippers must fully comply with established policies and procedures;
- All regularly scheduled school trippers must be published on public timetables;

³ Source: lacmta.sharepoint.com/sites/MyMetro/Operations/Pages/Home.aspx

⁴ Figures taken from October 2019 data; selected for seasonal average and adjusted for Blue Line closure.

- All locations where trippers board or alight customers, including the bus stops at deviated routes, must be marked with Metro signage including the bus line numbers servicing the stop;
- School tripper changes must be provided to the public by a service change notice or on the Metro website at www.metro.net; and
- Requests for new school trippers or modifications to existing school trippers will be considered when a notice is given at least two weeks in advance providing ample time to complete an appropriate analysis of the request and to allow appropriate notification of changes to the public.

School tripper services changes must comply with the following procedures

- Service Development Managers (SDM) in the Service Planning & Scheduling Department are responsible for certifying that all school trippers in their respective service area fully comply with Metro’s School Tripper Policy as discussed herein. Each SDM will submit a report prior to each major service change program that details all existing and proposed school tripper service.
- School tripper “pink letters” require notification to the public through use of a service change notice or on Metro’s webpage.
- Uniform standards for the documentation of school tripper pink letters must be employed. This includes standardizing the pink letter form and oversight of the pink letter information being input into the SLS 2000 system to ensure accuracy. All requests for new school trippers and modifications to existing school trippers must be logged into the SLS2000 regardless if the requested new or modified school tripper is implemented.
- SDMs are responsible for working with school districts in their service area which use school tripper service. For example, a specific protocol has been established with LAUSD in which their monthly Operations Coordinators’ Meeting has a standing agenda item, “Metro Coordination,” where special events and bell-time changes are disseminated to Metro through communication with staff and the meeting’s minutes.

3.5 Charter Service

As a grantee of Federal funds, Metro is prohibited from using its federally-funded equipment and facilities to provide charter service except on an incidental basis and when one or more of the applicable exceptions below apply:

- Charter service shall be incidental to the mass transportation service and shall be provided only during times of the day when vehicles are not needed for regularly scheduled service.
- Charter service will only be considered when one of the following exceptions apply:
 - There are no willing or able private charter operators;
 - For special events the private operators are not capable of providing the service;

- When there is a formal agreement regarding the provision of charter services between the recipient and all private charter operators who have been identified to be willing and able; and
 - For government or certain non-profit organizations, if the trip involves a significant number of handicapped persons, or if the organization is a qualified social service agency, or if it receives public welfare assistance funds whose implementation may require transportation services.
- All requests for Charter Service must be approved by the Chief Executive Officer and may require a waiver from the Federal Transit Administration. Petitions for a waiver should be requested in writing 90 days in advance of the event whenever possible.
 - The rates for charter service shall equal or exceed the annual fully allocated cost, including depreciation, of providing charter bus operations, and Metro shall deduct the mileage and hours from the useful life of the buses.
 - The operation of charter service also must comply with relevant state laws, including Section 30630.5 of the California Public Utilities Code.

Charter service is the use of buses, vans or facilities (rail system) to provide a group of persons under a single contract, at a fixed charge, with the exclusive use of the vehicle or service to travel together under an itinerary either specified in advance or modified after having left the place of origin. Generally, for service not to be considered charter, it must meet the following tests:

- Be available to the public;
- Operate within the system’s normal scope (existing routings, fit within normal hours of operation and established fare structure);
- Provide a published timetable; and
- Customers must pay their own fare.

3.6 Special Event Service

Special event services are bus routes designed to take customers to a specific venue and are not part of regularly scheduled operations. Metro will provide service under contract to other entities only if the provision of these services does not interfere with Metro’s ability to meet regularly scheduled service obligations and fits within the scope of the agency’s regular operation in terms of route structure, fares, and span of service. Special event services will be provided on a full cost recovery basis and in conformance with the agency’s charter bus policy.

3.7 Service Transfer Guideline

The regional public transit network consists of 17 “Included or Eligible” fixed route operators (including Metro). Included operators (and routes) are those that were operating within LA County in 1971 at the time of adoption of the TDA/STA statute. Eligible operators (and routes) are those added to the Formula Allocation Procedure (FAP) since that time.

Much of the funding for operation of “Included or Eligible” fixed route public transit service in LA County is distributed according to an adopted FAP. The FAP allocates sales tax receipts for public transit each fiscal year in support of public transit throughout the region. Many of the “Included and Eligible” systems operate under the guidelines of the “reserve service areas” established in 1971. Municipal operators have also grown, providing an expanded route network that has improved connections to Metro’s regional lines. In addition, there are numerous Local Return fixed route transit providers who are not eligible for FAP funding, but instead are funded through Propositions A and C (1990 sales tax initiative), Measure R (2008 sales tax initiative), and Measure M (2016 sales tax initiative). These Operators are funded as “Local Return” operators (see Appendix B for a list of operators funded as Local Return and/or Included/Eligible Municipal operators).

Policy guidance states that the network should be well integrated, coordinated, reduce service duplication, and simplify service. Therefore, the evaluation of transit corridors for consideration to be operated in the future by another operator should include:

- Existing performance relative to the system average;
- Value to the customer through integration into an established nearby transit provider;
- Net cost to each operator and the region;
- Completion of another operator’s route network;
- Provide improved connections to a Municipal Operator’s established network;
- Impacts to exiting and projected ridership;
- Generation of a net cost savings to Metro based on Metro’s calculation of the FAP impacts for all service realignment proposals.

Any transfer of directly operated Metro services to a municipal or contract operator must adhere to the terms and conditions governing such transfers as agreed to within the adopted collective bargaining and other superseding agreements between the affected labor unions and Metro.

If a proposed service change is adopted that results in a reduction of service, Metro should reinvest at least half of the net savings (operating cost less customer and FAP reduction) to improve service on Metro’s core network of regionally significant lines in the service area from which the savings were drawn.

Any significant service modifications will be subject to review under Title VI of the Civil Rights Act of 1964, as amended, the approval of the appropriate Metro Service Council(s) and the local transit provider’s Board of Governance, and must be in compliance with local, regional, and labor legislation or agreements. Finally, the agency that assumes service will be required to maintain or improve the days, spread, and frequency of the exiting service for at least a one-year period. In addition, the assuming agency must be a participant in the regional TAP program to minimize fare change impacts.

3.8 Alternative Service Delivery Options

Alternative service delivery options generally refers to services not directly operated by Metro, such as contract services, Municipal and Local Return Operators, taxis and other flexible destination operations. These alternatives can complement traditional transit service. In addition, Access Services provides mandatory ADA complimentary paratransit services for functionally disabled individuals in Los Angeles County. Access transportation service is available for any ADA paratransit eligible individual to any location within $\frac{3}{4}$ of a mile of any fixed bus operated by the Los Angeles County public fixed route bus operators and within $\frac{3}{4}$ of a mile around Metro Rail stations during the hours that the systems are operational. Complimentary paratransit service is not required to complement commuter rail and commuter bus services, since the ADA does not require that these services provide complementary paratransit service.⁵

Metro has launched two pilot programs to leverage demand-responsive technology to improve mobility, customer experience, and system performance by providing additional first-mile and last-mile service options: Mobility on Demand and MicroTransit.

The Mobility on Demand pilot launched in January 2019 and will operate for 12 months. Metro has partnered with Via, a provider of on-demand shared rides, to develop on-demand technology to increase access to Metro's transit system by offering service to and from three of Metro's transit stations: North Hollywood, Artesia, and El Monte. This pilot program is funded in part by a \$1.35-million Mobility on Demand (MOD) Sandbox Demonstrations grant from the Federal Transit Administration (FTA).

The MicroTransit Pilot Project is anticipated to launch in late 2019. Metro is partnering with RideCo, NoMad/Via, and Transdev to develop on-demand technology to increase access to Metro's transit system. MicroTransit short trips will be approximately 20 mins in vehicle and run one to five miles in distance. These short trips may connect customers to Metro operated services and to municipal operators.

⁵ https://accessla.org/riding_access/overview.html

SECTION 4: CUSTOMER INFORMATION AND AMENITIES

Customer information instructs both regular customers and infrequent customers on how to use transit as a viable mode of transportation to and from their destinations. Clear, accurate, and timely information is an important adjunct to service quality, particularly when bus and rail services are not operating as planned. Amenities aid in the comfort and security of customers.

4.1 Customer Information

Customers need to know how to use transit: where to go to access it, where to alight to access their destination, whether transfers are required, when transit services are scheduled to depart and arrive, and how planned and unplanned service changes or disruptions impact travel. Both regular and infrequent users require specific route information when they need to travel to a location they rarely visit or that is new to them. Information must be provided in accessible formats. Metro provides customer trip planning and help information via telephone, customer service representatives, on-board announcements, mobile device applications and text/SMS messaging, by mail, online at the metro.net website, and by email.

- **Signage** at transit infrastructures such as stations and shelters, signs directing motorists to Park & Ride lots, and bus stop signs that indicate the presence of service to people not currently using transit.
- **Audible Announcements** at bus stops, rail stations and on-board vehicles to assist customers with visual impairments and customers unfamiliar with the route or area.
- **Online Information** is available 24-hours to anyone with Internet access such as:
 - Nextrip’s next bus arrival (detour notices should be posted on this service, Metro’s website, as well as other transit applications)
 - Google, Apple, and Bing Maps
 - Route maps and timetables, fare information, and Trip Planner
 - Specialized guides (Bikes, Riders with Disabilities, Safety & Security)
 - Commuter program information (carpools, vanpools, employer programs, etc.)
 - News and media information
 - Latest projects and programs
 - Contact information
 - Special event information
 - Social media accounts
- **Bus and Train Real-Time Information:** Accurate, timely, relevant, and readily available trip information is useful for reassuring customers when the next transit vehicle will arrive or how long the expected delay time is if there has been a service disruption. It should provide them with enough information to help them decide whether to continue to wait for the next transit vehicle, consider alternate routes, or take another mode of transportation to complete their trip.
- **Printed and Distributed Information**, such as timetables, maps, service change notices, customer newsletters, etc., preferably available at multiple locations.

- **Posted Information**, such as system maps, bus cubes posted at stops, stations, and on board transit vehicles.
- **Route Numbering Convention** at stops and on transit vehicle head signs assist customers to quickly identify what stops to wait at and what transit vehicle to board related to printed and posted information. See Appendix A.
- **Wayfinding** is the process of communicating information to support the ability to navigate using signage, system/route maps, kiosks, bus cubes, directions, etc. so that customers can easily determine where they are, where they want to go, and how to get there.
- **Visual Displays** to assist customers with hearing impairments and to supplement on-board announcements that may be muffled by other noise.
- **Customer Information Panels (CIPs)** are interactive touch screen panels that display vehicle arrivals, service alerts, system and local maps, Metro Arts programming, advertising, and Agency PSAs.

4.2 Customer Amenities

Customer amenities are those elements provided at a transit stops, transit centers, and station stops to enhance comfort, convenience, and security. Amenities include items such as shelters, benches, vending machines, trash receptacles, lighting, restrooms, and telephones. In some instances, Metro coordinates with municipalities to provide appropriate amenities. Metro provides a minimum set of customer amenities at all rail stations and major Metro-owned off-street bus facilities that allow for boarding as summarized in Table 4.1.

- **Benches** provide comfort for waiting customers, help identify the stop or station, and provide an affordable alternative to shelters.
- **Elevator/Escalators** provide accessibility for those who otherwise cannot use stairs to elevated or lowered station stops.
- **Lighting** increases visibility, security, and discourages misuse of bus stops when transit operations are not in service.
- **Public Restrooms** may be provided at major transit centers and maintained for public safety and convenience.
- **Shelters** provide comfort for waiting customers, protection from climate conditions, and help identify the stop or station. Metro does not own or install benches and shelters but will coordinate with local jurisdictions on their placement where appropriate.
- **Telephones/Intercoms** provide access to transit information and emergency services.
- **Trash receptacles** provide a place to discard trash and contribute to keeping bus stops and surroundings clean. Trash receptacles are placed and maintained by individual municipalities at bus stop locations.

Table 4.1 *Customer Information and Amenities*

Amenity	Service Type	Allocation
Shelters:	Heavy Rail:	n/a
	Light Rail:	At least 80 linear ft. per bay
	Bus Facilities:	At least 6 linear ft. per bay
Seating:	Heavy Rail:	At least 12 seats
	Light Rail:	At least 10 seats
	Bus Facilities:	At least 3 seats per bay
Info Displays:	Heavy Rail:	At least 12
	Light Rail:	At least 10
	Bus Facilities:	At least 3
LED Displays:	Heavy Rail:	At least 8 arrival/departure screens
	Light Rail:	n/a
	Bus Facilities:	n/a
TVMs:	Heavy Rail:	At least 2
	Light Rail:	At least 2
	Bus Facilities:	n/a
Elevators:	Heavy Rail:	At least 2
	Light Rail:	At least 1 for elevated/underground
	Bus Facilities:	At least 1 for multi-level terminals
Escalators:	Heavy Rail:	At least 4 (2 Up/2 Down)
	Light Rail:	n/a
	Bus Facilities:	n/a
Trash receptacles:	Heavy Rail:	At least 6
	Light Rail:	At least 2
	Bus Facilities:	At least 1 per 3 bays/2 per facility

4.3 Rail Stations and Major Off-Street Bus Facilities

When transit service is not provided near one’s origin, driving to a Park & Ride lot or utilizing another first-last mile option such as a bicycle or scooter to transit may be viable alternatives. Park & Ride lots, bicycle storage, and micro-mobility parking areas are important amenities for transit customers.

- **Park & Ride/Station Parking Facilities** provide parking for transit customers who use their cars to access a bus or train. Park & Ride facilities are usually provided at station stops or transit centers such as the Metro El Monte Station, Harbor Gateway Transit Center, and at various rail stations. Park & Ride lots also can be found in suburbs to serve as a staging area for commuter customers.

- **Bicycle Storage** may be provided at transit stations where demand exists and space allows, and on transit vehicles. Bicycle racks, lockers, and hubs may be provided at transit center and stations. On transit vehicles, bicycles may be transported on bus-mounted racks located in front of a bus or on board a rail car in designated spaces. Bike racks provide a simple, relatively low-cost approach and can hold many bicycles in a relatively small space, but bicycles are subject to potential damage and theft. Enclosed bicycle lockers and hubs provide added protection from theft and from weather but cost more and require more space.
- **Micro Mobility Vehicle Parking** is being tested at key Metro system locations as a pilot program. At their July 25, 2019 meeting, the Metro Board adopted a parking ordinance to regulate parking of electric scooters and other similar devices. As part of the pilot, Metro has designated parking areas at select stations and transit hubs for parking of devices; the private firms seeking to park their vehicles at Metro sites must pay a fee for use of the parking facilities.⁶

4.4 Bus Stop Amenities

There are no standards for bus stop amenities because apart from painting the curb red and erecting bus stop signage, Metro has no jurisdiction over street-sitting fixtures or other appurtenances; those are installed by the municipality where the stop is located and often contracted to third parties who support installation and maintenance through advertising revenues.

Transit services are supported by bus stop, transit center and stations facilities. These locations are often the first and last points of contact with the customer. These facilities are an essential component of transit infrastructure that direct customers to existing transit services, provide a safe and comfortable environment in which to wait for service, and facilitate safe and efficient transfers between services. Given their importance, it is vital that transit routes and schedules are developed in consideration of the quality, appropriateness, and availability of facilities.

Bus stops are locations along the route of a bus line where customers safely wait to board or alight from a bus in service. Bus stops consist of a pole with a sign that includes route line number, destination and service qualification signage, and curb markings or parking restriction signage. Select bus stops also include a bus information cube affixed to the pole. Most bus stops are located along the curb of a street; others are located at offsite facilities such as transit centers or rail stations that are owned and maintained by the local municipality or by Metro.

Transit stations are stops along a fixed guideway and have features such as loading platforms, TVMs for fare pre-payment, shelters, benches, lighting, information displays, trash receptacles, bike racks and lockers, and emergency call boxes. Many are located adjacent to Park & Ride lots and customer pick-up/drop off areas.

⁶ Planning and Programming Committee File #2019-0085; LACMTA Administrative Code Title 8: Metro Parking Ordinance

Transit centers are high volume transfer points for multiple transit services and layover spaces for end-of-line bus storage and turn around. Features include customer loading and alighting areas, benches, shelters, lighting, information displays, bicycle racks and lockers, trash receptacles, and bus layover bays.

On-street bus layover zones are designated stopover points for buses at or near the end of the line. They may or may not allow for customer boarding and alighting. Bus terminals are major offsite layover areas for multiple bus lines and may or may not allow for customer boarding and alighting.

Locating bus facilities (other than on-street stops) in heavily congested or urbanized areas increases the burden on the transit operator to find layover spaces for buses and operator restrooms. The extension of a line to a specific terminal may prove uneconomical and at the very least add costs to an already budget constrained operation.

Cost and minimization of customer disruptions are significant concerns when locating facilities for bus operations. Metro Operations continues to evaluate routes and layovers to reduce costs and improve efficiency. As a key internal stakeholder in the environmental planning process, the Service Development Department should be involved early in the analysis of alternatives to and the development of mitigation measures to ensure adequate accommodations are incorporated to foster connectivity of future projects.

Capital costs of new support facilities are an important determinant; but more significant is the added operating cost that may be incurred due to inadequate facilities.

4.5 Bus Stop/Station Location, Design and Guidelines

Bus stops and station stops allow for boarding and alighting of customers; their locations should balance safe, convenient access with pedestrian safety. Locations should support efficient transfers, minimize walking distances and unnecessary crosswalk movements, and preferably be located at a signalized crosswalk to prevent potential jaywalking. Bus stops are generally located adjacent to a bus/rail station or within a short walk to medical facilities, schools, shopping centers, office buildings, multi-unit apartments, or other major activity centers to provide access for uses that generally attract transit customers. Hospitals and schools have high priority when considering new bus stop locations and/or when relocating existing bus stops.

BRT/Rail station locations are determined during the design phase of a fixed guideway/right-of-way. There are criteria associated with station location, but this is beyond the scope of this TSP. Generally, stations are located at major transfer points with bus or rail and provide access to major activity centers. No standard type of stop can be recommended for all locations, as each intersection has its own unique characteristics. An inventory of land uses that serve as major trip producers and attractors within a 0.25-mile corridor of the road under consideration should be taken prior to establishment. The location of a transit stop requires concurrence of the municipality in which the stop is located in.

In general, far-side stops are preferable, particularly at signalized intersections; however, near side or mid-block stops may be justified in certain situations. A summary of advantages and disadvantages to each location are provided in Table 4.2. TCRP Report 19 “Guidelines for the Location and Design of Bus Stops” (1996) provides a more detailed discussion.

Table 4.2 *Comparative Analysis of Bus Stop Locations*

Stop Type	Advantages	Disadvantages
Near-Side	<ul style="list-style-type: none"> ▪ Minimizes interference when traffic is heavy on the far side of the intersection ▪ customers access buses closest to crosswalk ▪ Intersection available to assist in pulling away from curb ▪ Buses can service customers while stopped at a red light ▪ Provides driver with opportunity to look for oncoming traffic including other buses with potential customers 	<ul style="list-style-type: none"> ▪ Conflicts with right turning vehicles are increased ▪ Stopped buses may obscure curbside traffic control devices and crossing pedestrians ▪ Sight distance is obscured for crossing vehicles stopped to the right of the bus. ▪ The through lane may be blocked during peak periods by queuing buses ▪ Increases sight distance problems for crossing pedestrians
Far-Side	<ul style="list-style-type: none"> ▪ Minimizes conflicts between right turning vehicles ▪ Provides additional right turn capacity by making curb lane available for traffic ▪ Minimizes sight distance problems on approaches to intersection ▪ Encourages pedestrians to cross behind the bus ▪ Requires shorter deceleration distances for buses ▪ Gaps in traffic flow are created for buses re-entering the flow of traffic at signalized intersections ▪ Allows bus routes that operate signal priority to take advantage this technology at signalized intersections. 	<ul style="list-style-type: none"> ▪ Intersections may be blocked during peak periods by queuing buses ▪ Sight distance may be obscured for crossing vehicles ▪ Increases sight distance problems for crossing pedestrians ▪ May increase number of rear-end accidents since drivers do not expect buses to stop again after stopping at a red light
Mid-Block	<ul style="list-style-type: none"> ▪ Minimizes sight distance problems for vehicles and pedestrians ▪ Passenger waiting areas experience less pedestrian congestion 	<ul style="list-style-type: none"> ▪ Requires additional distance for no-parking restrictions ▪ Encourages customers to cross street at mid-block (jaywalking) ▪ Increases walking distance for customers crossing at intersections and for transferring customers

Source: FTA webpage (http://www.fta.dot.gov/12351_4361.html)

When two or more bus routes operate along the same corridor, stops should be consolidated to avoid unnecessary crosswalk movements and minimize confusion as to which stop customers should wait to catch their bus wherever possible. However, if a group of bus lines operating along the same street, in the same direction, serving the same intersection (such as in the downtown environment), it may be necessary to implement two stop locations (e.g.

nearside and farside) to minimize congestion and negatively impact bus operations under the following circumstances:

- Some bus lines will queue up to make a right turn while other lines continue through the intersection (unsafe right turn movements)
- Lack of space availability and no room to lengthen zone due to business owner objection, jurisdiction refusal to extend, a loading zone being located behind the current stop, etc.)
- Bus Stop/Station Accessibility: All stops and stations should be fully accessible in accordance with the 1990 Americans with Disabilities Act. This includes ensuring there are no obstructions preventing the boarding and alighting of customers who use a wheelchair or other assistive mobility devices, and that pathways to and from a stop or station are unobstructed. If obstructions do exist, every effort must be made to mitigate the issue(s) with the respective municipalities. In the case of bus stops, they can either be moved to a new location on a permanent basis or temporary basis depending on situations, such as during construction.

The following renderings (Figures 4.1 – 4.4) illustrate a typical bus stop/zone design and offers guideline for near-side, far-side, and mid-block locations. TCRP Report 19 “Guidelines for the Location and Design of Bus Stops” (1996) provides a more detailed discussion.

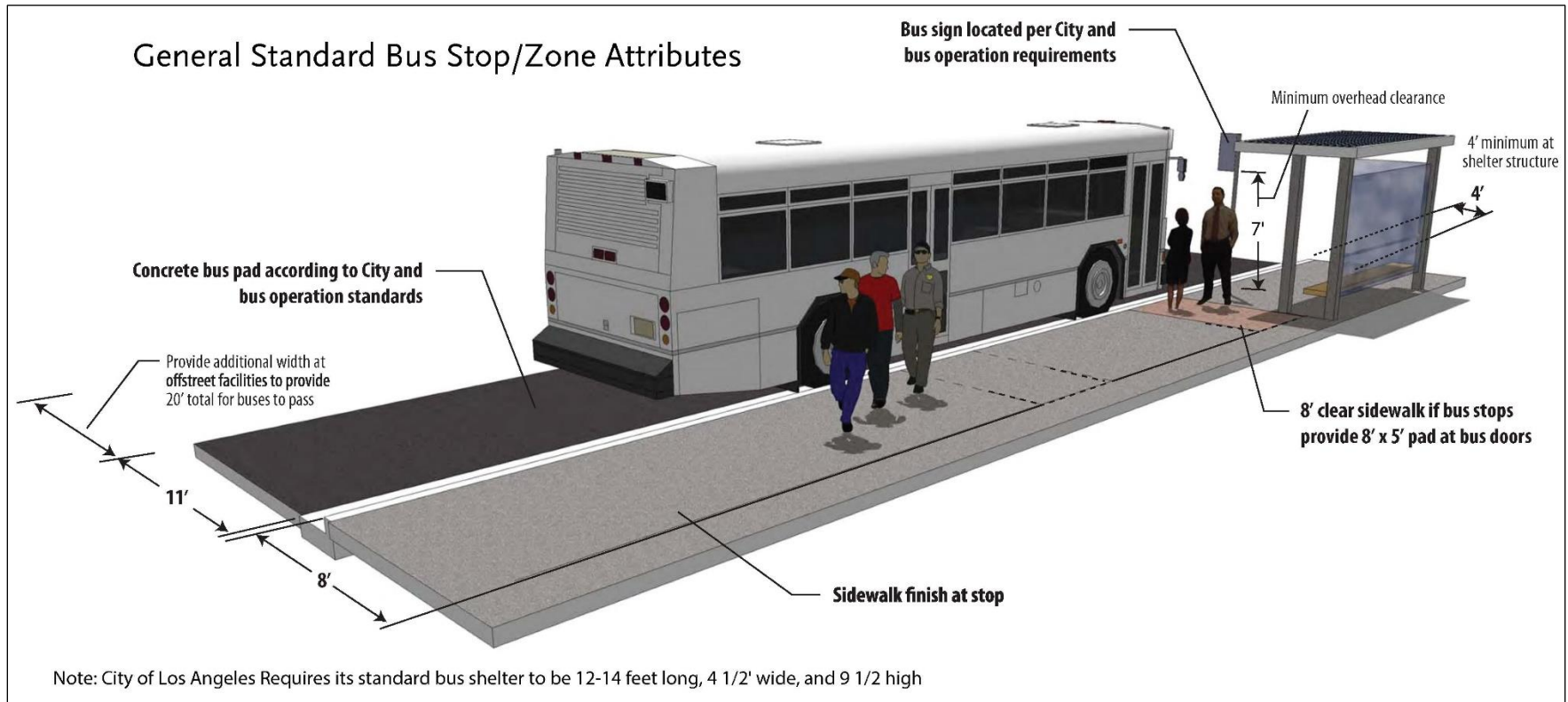

Figure 4.1 General Standard Bus Stop/Zone Attributes

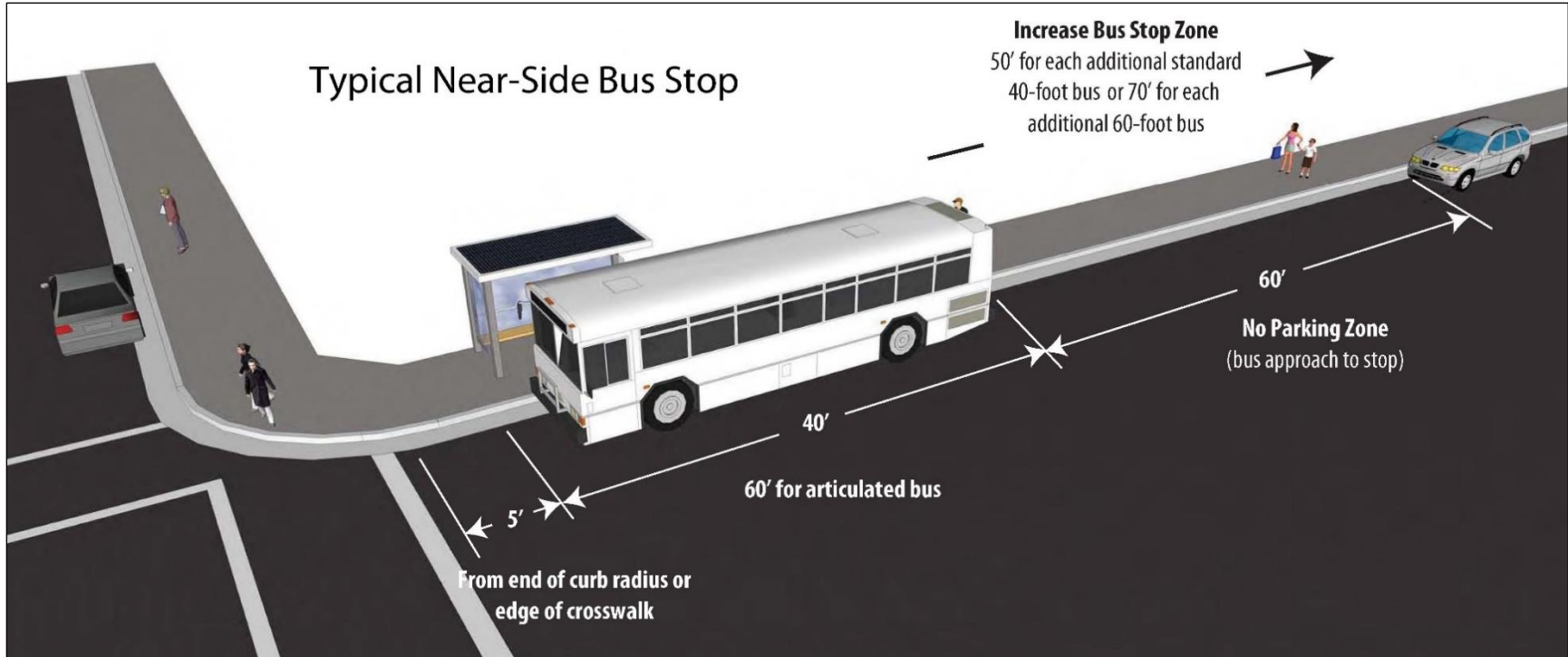

Figure 4.2 Typical Near-Side Bus Stop

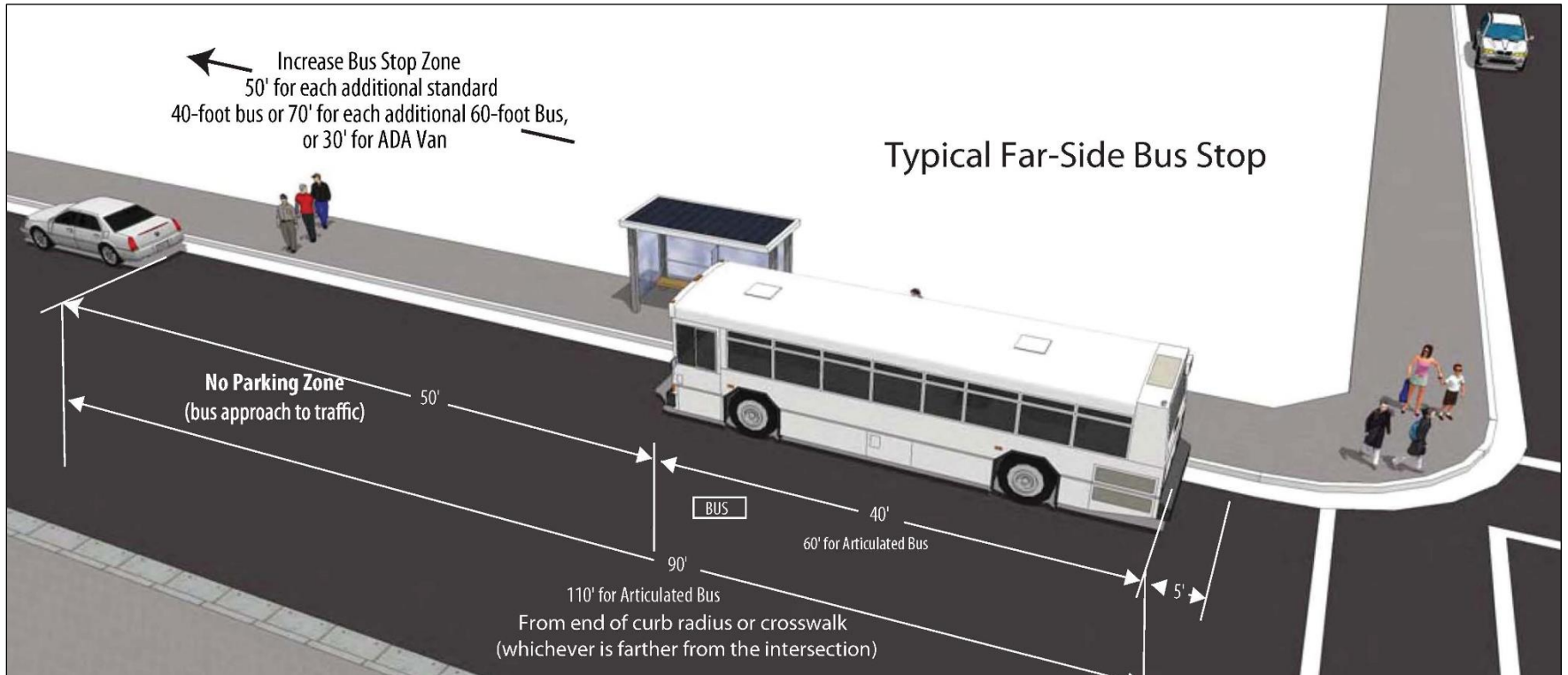

Figure 4.3 Typical Far-Side Bus Stop

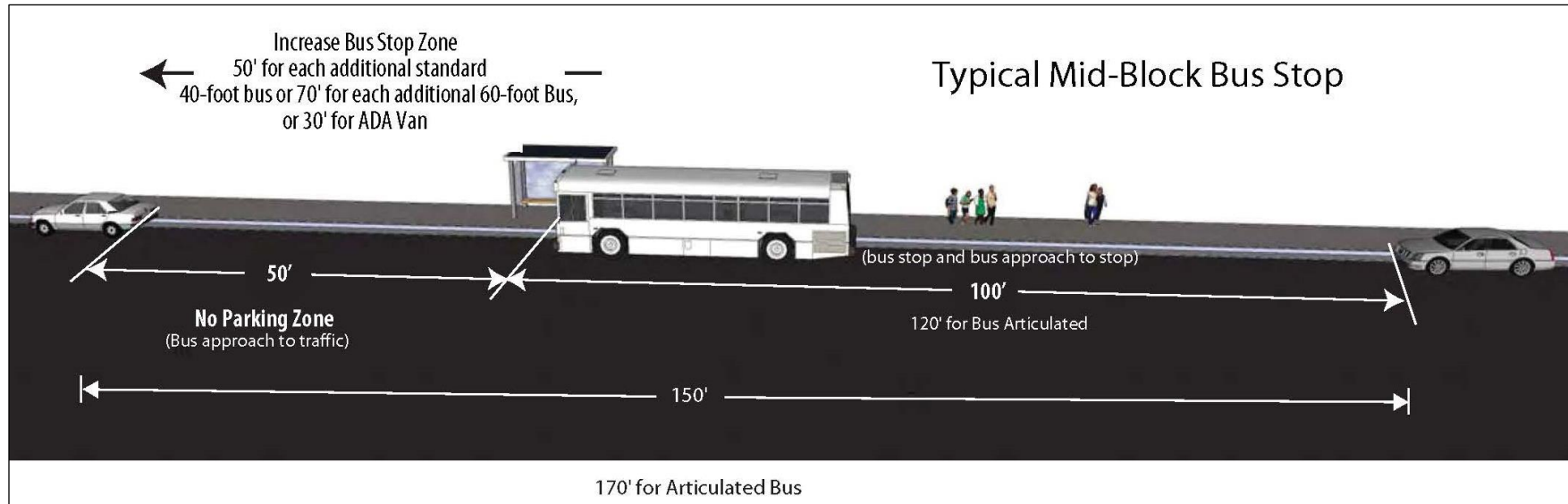

Figure 4.4 Typical Mid-Block Bus Stop

SECTION 5: SERVICE PERFORMANCE EVALUATION

The 2019 Metro TSP establishes a set of performance criteria and standards that balances optimization for efficiency and productivity with customer experience measures of success. Optimization of key performance indicators ensures that the services being provided generate the maximum benefit in terms of ridership at the lowest cost. Customer experience criterion measure how well the transit system can attract customers to use the system more often and for new trip purposes.

5.1 Route Performance Index

The Route Performance Index (RPI) is a conventional industry measure used to ensure Metro services are effective and provide a reasonable return on investment. The RPI is designed to provide an objective measure of bus route performance relative to system performance. The index is based on system ridership and financial targets from the current fiscal year Metro Budget.

This measure is applied to all Metro bus lines that have been in operation for more than one year. The RPI is used to identify under-performing lines. Specific corrective actions are taken during the service change process. Corrective actions may include marketing, service restructuring, implementing an alternative service, or discontinuation of service.

Defining RPI Variables

The RPI considers the following three variables in creating the index. No weight is given to an individual measure; rather the selected statistics represent all facets of the operation in terms of cost efficiency, service effectiveness, and customer use.

- **Utilization of Resources:** Passenger Boardings per Revenue Service Hour (RSH) is used as a measure to determine how effectively resources are used on a given line. This measure is determined by dividing the total number of boardings by the RSHs operated. A route having a higher number of boardings per RSH represents a better utilization of resources such as buses, operators and fuel.
- **Utilization of Capacity:** Passenger Miles per Seat Mile is the measure used to evaluate how the seating capacity of the system is being used. Passenger miles are calculated by multiplying the average distance traveled per customer by the number of customers using the service. Seat miles are calculated by determining the number of seats per vehicle by the number of service miles operated. A higher resulting number indicates greater utilization of system capacity.
- **Fiscal Responsibility:** Subsidy per Passenger is the measure for fiscal responsibility. Subsidy refers to the amount of public funding required to cover the difference between the cost of operation and the customer revenues collected. Higher subsidy services require more public funding support.

The formula for calculation of the RPI for each Metro Bus line is as follows:

$$\text{RPI} = ((\text{Passengers/RSH/System Avg.}) + (\text{Passengers Miles per Seat Mile/System Avg.}) + (\text{Subsidy per Passenger / System Avg.}))/3$$

Lines with an index of 1.0 perform at the system average, while lines with an index of less than 1.0 perform below the average. Lines with an RPI lower than 0.6 are defined as performing poorly and targeted for corrective action. Lines that have been subjected to corrective actions and do not meet the 0.60 productivity index after six additional months of operation may be discontinued, subject to Metro Service Council and Board approval.

The RPI is calculated and reported quarterly by Metro's Service Planning & Scheduling Department. The performance measurement standards for each route are set annually relative to the percentage improvement of overall system performance relative to the previous year's performance. This percentage improvement will be based on the performance objectives outlined in the Metro Annual Operating Budget.

5.2 Customer Experience

Providing high quality mobility options that enable people to spend less time traveling on the transit network requires that we are available when and where our customers want to travel, we are competitive enough to have them try us over other options, and we are attractive enough to ensure they return for the same trip and ideally for more trips. Therefore, our recommended measures of success are aimed at evaluating the bus network within these three stages of Find, Try, and Rely. These customer focused measures help to balance our traditional metrics of productivity and efficiency (e.g. ridership, boardings per hour, subsidy per boarding). Several of these measures (italicized below) will be used to evaluate the network through the lens of equity.

Find - How well do people understand how effectively transit can serve their needs? Is the system easy to understand and use? Proposed measures include:

- Services and information is Readily Available
 - Percentage of trip ends within ¼ mile of transit stop
 - Trip planner, app, and website usage rates
 - *Percent of public considering transit (survey-based)*
- The Bus System is Easy to Understand and Use
 - Percentage of out of direction travel
 - Percentage of route miles with all-day frequent service (<15 min headways)
 - *Percent of public understand how to use system (survey-based)*

Try - How can we encourage customers to try the regional transit system? (Metro and Municipal Bus Operators) Proposed measures include:

- Bus Goes Where/When Customers Want
 - *Percentage of trips compatible with transit by time of day and day of week*
 - *Number of jobs and activity centers accessible within a 15 minute and 30 minute transit ride*
 - Number of unique transit users

- Bus system is Competitive
 - *Door-to-door travel times*
 - *Competitiveness of transit time to drive time*
 - System-wide boardings
- Coverage is Adequate
 - *Population within ¼-mile of transit stops by frequency of service*
- Transit Journeys are Simple
 - Average number of transfers
 - Percent of trips that are one-seat rides

Rely - How can we provide services that customers can rely on for their travel needs? Proposed measures include:

- Bus System is Effective and Productive
 - *Competitive transit paths for short, evening, midday, and weekend trips*
 - Number of frequent customers
 - Boardings by time of day and day of week
 - Boardings per revenue hours and miles
 - Cost per passenger mile
- Buses are Reliable
 - Headway regularity on frequent routes
 - On-time performance
 - Real time arrival accuracy
- Customers are Satisfied
 - Rides per week for frequent and infrequent users
 - *Percentage of customers satisfied with Metro services (survey-based)*

5.3 Service Evaluation Process

Services are evaluated monthly, quarterly, and biannually based on the network, lines and segments (geographic, time of day, and day of week) . Services that are inconsistent with demand or do not meet system standards are identified for restructuring, reduction, or discontinuation. Services that have potential for exceeding existing performance will be identified for possible enhancements as should markets that are currently not well served. The following priorities will be considered when restructuring the Metro system:

- **Priority 1** – Restructure services to increase system speed, on-time performance, and balance loads.
- **Priority 2** – Restructure services that are duplicative with Metro Rail, other Metro Bus routes, and Municipal and Local Return operator services. Such services will be identified for discontinuation, consolidation, reduction and/or reallocation to achieve greater productivity and cost efficiency.

- **Priority 3** – Restructure remaining services (constrained by existing budget) based on the service concept and to address major gaps and deficiencies. Prioritize these service adjustments.
- **Priority 4** – Develop new services (unconstrained) to address all gaps and deficiencies. Prioritize these new services.

Significant changes to municipal operator services are incorporated into the evaluation of existing and new services as possible enhancements to address identified gaps or deficiencies in service.

Service Change Performance Evaluation

Schedule adjustments to bus or rail should be evaluated shortly after implementation to determine if there are any obvious issues. This should include line rides and visits to the operating divisions to receive comments and recommendations from customers, operators and supervisors. Appropriate adjustments should be made as required. After three months of operations, the schedules should be evaluated in detail to begin the process of schedule adjustments for the next service change cycle.

Route modifications to bus service should also be evaluated shortly after implementation like the schedule evaluation outlined above. The overall goals of the service changes such as reducing costs, improving connections, increasing bus speeds, and increasing ridership, among others, should have near term goals that are established prior to the service change process. At about 6 months after service implementation, the performance of the changes should be evaluated relative to the established goals. Remedial actions, if necessary, should be developed and considered for the next service change cycle.

SECTION 6: SERVICE CHANGE PROCESS

In 2003 Metro created five localized service areas (Figure 6.1), each to be overseen by a Governance Council. In 2011, Metro restructured and re-established a centralized bus-controlled operation to include the service planning and scheduling function, while maintaining the authority and responsibility of the Councils to help coordinate service changes. Metro restructured the roles and responsibilities of the Governance Councils, now referred to as Service Councils.

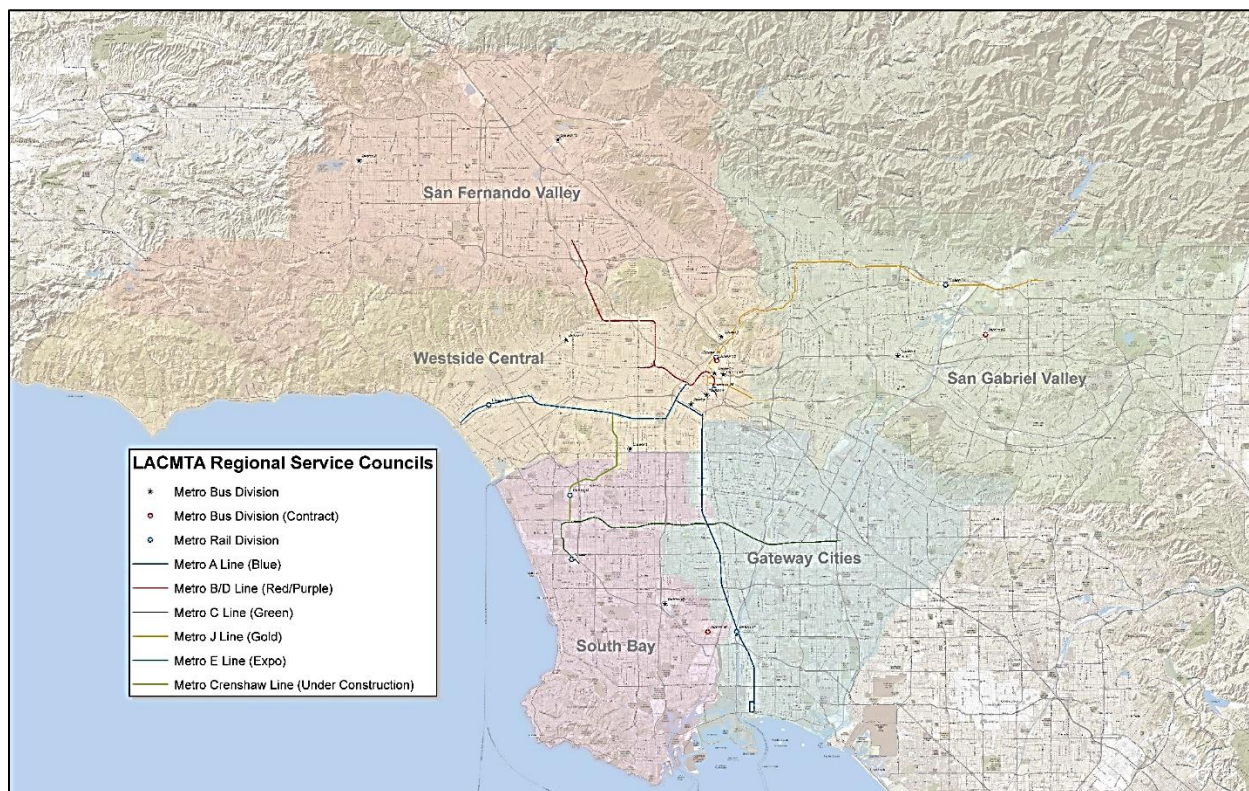

Figure 6.1 *Metro Service Council Areas*

Metro Service Councils provide locally accessible public forums for community members, transit users, and local municipal operators to voice concerns, suggestions, and questions on how Metro can best serve customers. Through these forums, Service Council members can:

- better understand customer needs and make recommendations;
- evaluate opportunities and service coordination issues;
- advise and approve the planning and implementation of service changes within their areas.

As stated in the 2011 update to the Service Council bylaws, one of the Service Council's primary responsibilities is to render decisions on proposed bus route changes considering staff's recommendations and public comments. Metro Service Councils (MSC) will be responsible for approving all proposed permanent route changes, excluding turnaround and out of service route modifications, which exceed a cumulative \$100,000 annual operating cost change. All

major service level changes that require public hearings will be brought to the MSCs who will conduct public hearings then vote to approve, modify, or deny the service change proposals. Any significant temporary service change should be brought to the Council for their information but not approval.

Each MSC will be responsible for holding public hearings that relate to major service changes to Metro bus and rail lines that provide significant service within their Region, consistent with State and Federal laws and with Metro policies pertaining to public hearings. Following receipt of public input, the Councils is responsible for approving all major service changes that are to be implemented that modify, add or delete Metro bus routes within the Service Council's jurisdiction in conformance with Metro service standards, collective bargaining agreements and Metro policies. When a major service change program requires three or more Councils to hold public hearings, an additional hearing will be held at a central location, normally at the Metro headquarters building, on an appropriate Saturday.

Table 6.1 *Service Change Timeline*

Key Activities	Required Lead Time (Months Prior to Implementation)
Initiate Planning Process	12
Develop Preliminary Recommendations	7-8
Impact Analysis for Proposed Changes	6-7
Title VI Equity Analysis on Major Service Change and Fare Change Proposals	5-7
Service Council Review and Input	6-7
Confer with Labor Relation and Union Representatives	6-7
Public Review and Input	5
Finalize Service Change Program	4-5
Program Approval	3-4
Develop New Service Schedules	2-4
Print Public Timetables and Operator Assignments	1-2
Fabricate Decals for Bus Blades	1-2
Take Ones/Rider Alerts on Buses	1

All route and major service changes that are approved by the MSC will be brought to the Metro Board of Directors as an information item. Should the Metro Board decide to move a Service Council approved service change to an Action Item, the Service Council will be notified of this change, prior to the next Service Council monthly meeting. Table 6.1 provides the established service change timeline.

6.1 Service Change Programs

Service change programs are developed based on input generated by a wide variety of sources including customer and employee input, service restructuring studies, requests from other local operators, and performance monitoring results. The service change process includes public review of the proposals, a technical evaluation of ridership impact, and Title VI equity analysis. In accordance with contractual agreements with the Sheet Metal Air, Rail and Transit Union (SMART)⁷, bi-annual service changes will be implemented in June and December. Metro service changes are conducted to modify service based on customer demand, running time adjustments, performance monitoring results, and budget considerations. A service change process workflow is provided in Figure 6.2.

Other factors considered are service performance, availability of alternatives, and mitigation strategies. As part of the evaluation process, resource impacts to in-service hours and required vehicles are also tracked to ensure compliance with budget parameters. In summary, the purpose of an evaluation on proposed service changes is to:

- Define and evaluate the impact on customers
- Determine whether a proposed major service change or fare increase will have disparate adverse impact on minorities or a disproportionate burden on low-income individuals by performing a Title VI Equity Analysis
- Consider alternatives if a disparate adverse impact to minorities or disproportionate burden on low-income individuals are identified
- Develop appropriate mitigation measures if needed
- Determine whether a public hearing is required

Changes to the rail system occur less frequently. They generally relate to the opening of a new line or adjustments to the frequency or hours of operation for existing service. Changes in rail and bus service follow the same planning and implementation process.

6.2 Title VI and Metro's Equity Platform

Metro's Equity Platform was adopted in February 2017. The framework for equity begins with Title VI of the Civil Rights Act of 1964 which protects minority and low-income communities from disparate and disproportionate negative impacts as a result of major transit service changes.

⁷ The United Transportation Union (UTU) merged with the Sheet Metal Workers Union in 2014 to form SMART.

Figure 6.2 Service Change Process

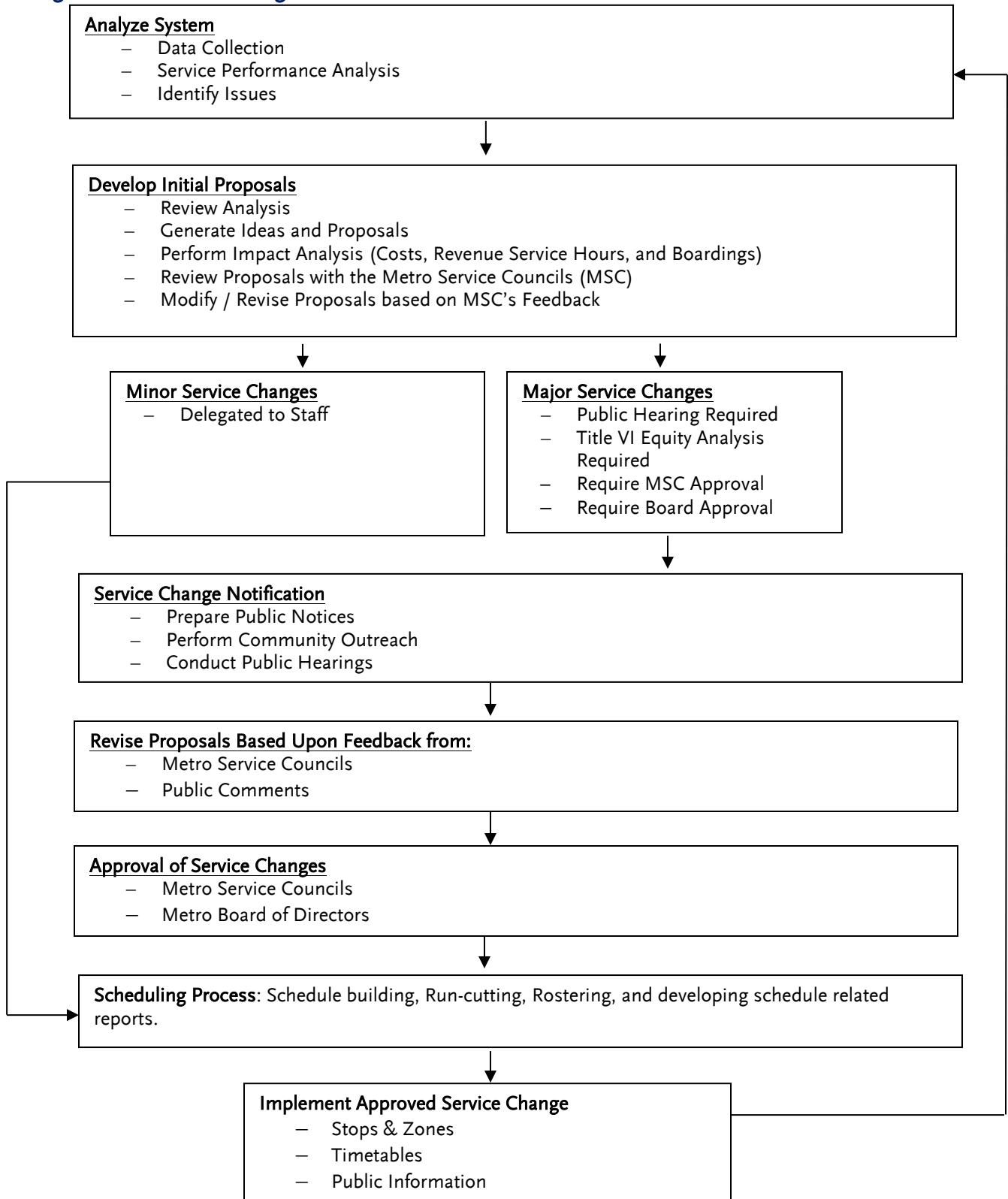

6.3 Title VI Equity Analysis

In addition, Metro will ensure a Title VI Equity Analysis is performed on all major service change and fare change proposals to determine if these proposals will have a disparate adverse impact on minorities or disproportionate burden on low-income individuals prior to a public hearing. If it is determined that these proposed changes will have a disparate adverse impact on minorities or a disproportionate burden on low-income individuals, Metro will make a good-faith effort to mitigate or reduce the adverse impacts by looking for alternatives.

The framework for equity begins with Title VI of the Civil Rights Act of 1964 which protects people from discrimination based on race, color, or national origin. Impacts on minority and low-income communities must be analyzed to identify disparate and disproportionate negative impacts resulting from a fare change or major transit service changes.

In accordance with FTA's Title VI Circular 4702.1B "Title VI Requirements and Guidelines for Federal Transit Administration Recipients" (Effective October 1, 2012), Metro's Administrative Code was revised to incorporate FTA's requirements under Title VI. The Metro Board adopted the updated Administrative Code in January 2013. Based on this Circular, Metro is required to perform a Title VI Equity Analysis on all proposed major service changes or fare changes prior to implementation. The goal is to ensure there is no *disparate adverse impact* to minorities or *disproportionate burden* on low-income individuals created by a major service or fare change. The following definitions and criteria were updated and adopted by the Board in September 2019. The Administrative Code now contains a reference to these definitions so that it need not be amended every time there is a need to modify the definitions:

Disparate Impact Policy:

Disparate impact refers to a facially neutral policy or practice that disproportionately affects members of a group identified by race, color or national origin and the policy lacks a substantial legitimate justification, including one or more alternatives that would serve the same legitimate objectives but with less disproportionate effects on the basis of race, color or national origin. This policy defines the threshold Metro will utilize when analyzing the impacts to minority populations and/or minority customers.

- a. For major service changes, a disparate impact will be deemed to have occurred if the absolute difference between the percentage of minority adversely affected and the overall percentage of minorities is at least five percent (5%).
- b. For any applicable fare changes, a disparate impact will be deemed to have occurred if the absolute difference between the percentage of minority adversely affected and the overall percentage of minorities is at least five percent (5%)

Disproportionate Burden Policy:

Disproportionate burden refers to a facially neutral policy or practice that disproportionately affects low-income populations more than those populations that are not low-income. A finding of disproportionate burden for major service and fare changes requires Metro to evaluate alternatives and mitigate burdens where practicable.

1. For major service changes, a disproportionate burden will be deemed to exist if an absolute difference between percentage of low-income adversely affected by the service change and the overall percentage of low-income persons is at least five percent (5%).
2. For fare changes, a disproportionate burden will be deemed to exist if an absolute difference between the percentage of low-income adversely affected and the overall percentage of low-income is at least five percent (5%)

Discretion of the Metro Board of Directors

A *major service change or fare increase* may be implemented even if the Title VI Equity Analysis determines a *disparate adverse impact* to minorities was created by the change. However, the Metro Board of Directors must first ensure these changes meet two tests:

- There is a substantial legitimate justification for adopting the proposed major service change or fare increase, meaning the selected service change or fare increase meets a goal that is integral to the mission of Metro; and
- The selected alternative would have a less severe adverse effect on Title VI protected populations than other alternatives that were studied.

Major Service Change

Major service changes are defined in Metro's Administrative Code in Chapter 2-50 Public Hearings Subsection 2-50-010 as any service change that meets at least one of the following criteria:

1. A revision to an existing transit route that increases or decreases the route miles and/or the revenue miles operated by 25% or more at one time or cumulatively in any period within 36 consecutive months since the last major service change;
2. A revision to an existing transit service that increases or decreases the scheduled trips operated by at least 25% at one time or cumulatively in any period within 36 consecutive months since the last major service change;
3. An increase or decrease to the span of service of a transit line of at least 25% at any one time or cumulatively in any period within 36 consecutive months since the last major service change;
4. The implementation of a new transit route that provides at least 50% of its route miles without duplicating other routes;
5. Six months prior to the opening of any new fixed guideway project (e.g. BRT line or rail line) regardless of whether or not the amount of service being changed meets the requirements in the subsections 1-5 above to be inclusive of any bus/rail interface changes.
6. Experimental, demonstration or emergency service changes may be instituted for one year or less without a Title VI Equity Analysis being completed and considered by the Board of Directors. If the service is required to be operated beyond one year the Title VI Equity Analysis must be completed and considered by the Board of Directors before the end of the one year experimental, demonstration or emergency.

7. A Title VI Equity Analysis shall not be required if a Metro transit service is replaced by a different route, mode, or operator providing a service with the same headways, fare, transfer options, span of service and stops.

Fare Changes

Any fare change requires an equity evaluation consistent with the following guidance:

1. A Fare Equity Analysis shall be prepared for any fare change (increase or decrease). This includes but is not limited to permanent fare changes, temporary changes, promotional fare changes, and pilot fare programs. The analysis will evaluate the effects of fare changes on Title VI protected populations and low-income populations. The analysis will be done for fares not available to the general public such as special discount programs for students, groups or employers.
2. If fare changes are planned due to the opening of a new fixed guideway project, an equity analysis shall be completed six months prior to opening of the service.
3. Each Title VI Fare Equity Analysis shall be completed and presented for consideration of the Board of Directors in advance of the approval of the proposed fare or fare media change by the Board of Directors. The Equity Analysis will then be forwarded to the FTA with a record of action taken by the Board.
4. A Title VI analysis is not required when:
 - a) A change is instituted that provides free fares for all customers;
 - b) Temporary fare reductions are provided to mitigate for other actions taken by Metro;
 - c) Promotional fare reductions are less than six months in duration. An equity analysis must be conducted prior to making any temporary fare change into a permanent part of the fare system.

6.4 Metro's Equity Platform

Metro's Equity Platform builds upon Title VI in two distinct ways. First, it goes beyond ethnicity and income to determine communities with the greatest mobility needs. Through market research, surveys, and public input, other groups most reliant on transit include non-English speaking new immigrants, youth and seniors, persons without access to an automobile either by choice or necessity, persons with disabilities, and women who tend to make more transit trips than men.

Second, NextGen Bus Study aims to go above and beyond Title VI, to not only protect against negative impacts, but to further improve service for communities with the greatest mobility needs. To do this, the Four Pillars of the Equity Platform have been integrated into the NextGen Bus Study planning and public engagement process.

- I. **Define and Measure** – Use Title VI as a baseline for identifying communities with the greatest needs, and supplement those with market research to identify the segments of population and trips with the highest propensity for transit use. Evaluate bus

network changes based on the customer focused performance metrics established within this report with particular focus on communities with the greatest mobility needs as identified above.

- II. **Listen & Learn** –The technical work of the NextGen Bus Study identified important information about Metro’s current and potential customers. This data was validated by the robust countywide public engagement effort, including engaging customers onboard buses, outreach sessions at community events, stakeholder briefings, interactive public workshops, digital engagement and print advertising. Comments received will be incorporated into the systemwide service design as well as individual route changes.
- III. **Focus & Deliver** – Service design concepts (discussed above) have been established to address the recurring themes identified from the public outreach and market research, including faster and more frequent service, better reliability and accessibility to key destinations, better connectivity particularly with the municipal operators, and improved perception of security on board buses and at bus stops. These concepts, described below, will be used to redesign the routes and schedules.

In addition, a Transit Propensity Index score has been developed and assigned to every Census Tract in Los Angeles County. This index score considers the various market segments likelihood to use transit, the transit orientation of the environment being served, and the travel demand within the area. Areas with high scores should be prioritized for high quality transit service.

Lastly, other customer experience enhancements such as improved security, accurate real time arrival information, cleanliness, and improved first/last mile service are critical to attracting customers to use transit.

- IV. **Train & Grow** – The Board adopted Transit Service Policy will be updated to reflect the Regional Service Concept as adopted by the Board, including the goals and objectives of the bus network, measures of success, route and network design concepts based on public input and data analysis, and framework for balancing tradeoffs in consideration of Metro’s Equity Platform. In addition, an annual monitoring program will be established to track the progress of achievement towards the goals and objectives, and to inform on necessary adjustments.

6.4 Public Outreach

Prior to a public hearing, several public outreach efforts are made so that the greatest number of customers may respond to the changes at either a public hearing or by submitting written comments at a hearing, or via email, mail, or fax. In accordance with Metro’s Administrative Code in Chapter 2-50 Public Hearings Subsection 2-50-025:

1. Any public hearing required by Section 2-20-020 shall be conducted as set forth in this section.
2. Notice of the hearing shall be published in at least one English language and Spanish language newspaper of general circulation and at least thirty (30) days prior to the date

of the hearing. Notice at least thirty (30) days prior to the date of the hearing shall also be published in the neighborhood and foreign language and ethnic newspapers as appropriate to provide notice to the members of the public most likely to be impacted by the proposed action.

3. Notice of the public hearing shall also be announced by brochures in English, Spanish and other appropriate languages on transit vehicles serving the areas to be impacted and at customer service centers.
4. To ensure that the views and comments expressed by the public are taken into consideration, MTA staff shall prepare a written response to the issues raised at the public hearing. That response should also include a general assessment of the social, economic and environmental impacts of the proposed change, including any impact on energy conservation.
5. The public hearing related to a recommendation to increase transit fares charged the public shall be held before the Board of Directors and any action taken to increase the fares charged the general public must be approved by a two-thirds vote of the members of the Board of Directors. The Board of Directors may delegate to another body or a hearing officer appointed by the Chief Executive Officer the authority to hold the public hearing related to a change in transit service.

Table 6.2 *Timeline for Public Notification Activities*

Activity	Months Prior to Service Change
Service Planning staff reviews preliminary proposals.	7
Metro Service Councils set dates of public meetings, publish hearing notices in local newspapers and send LEP and minority communities written notification to elected officials, other operators and key stakeholder groups. Confer with Labor Relations and Union representatives.	5-6
Service Planning staff provides information on proposed changes to the Metro Bus Operators Subcommittee and at quarterly meetings held with the region’s municipal and local operators.	3
Communication Department posts information proposed changes on Metro’s website.	5
Operations staff distributes meeting notices on board vehicles. Public outreach at key transportation centers, bus stops, and on-board customer interface occurs as well.	Minimum one month prior to public hearings
Metro Service Councils conduct public hearings.	4
Metro Service Councils approve final service change program.	3
Metro Board receives the Service Councils’ approved service change program as a Receive and File item.	2
Communication Department prepares press releases on final program and program brochures are distributed on-board Metro vehicles and other outlets.	1

The distribution of information will include line number, line name, route change information, and/or fare change proposals. Other public outreach occurs at key transportation centers, bus stops, and bus and rail stations 30 days prior to the public hearing date. These efforts are made to reach and engage customers who may not have time to attend a public hearing and to inform them of alternative communication methods available to file public comments. Public participation in the public hearing process is an important step in assisting staff and Metro Service Councils in developing and approving final service change proposals. Table 6.2 provides a timeline for public notification activities.

6.5 Public Hearing Process

Once a Service Change Program has been developed by Metro Service Planning Staff, the Metro Service Councils are asked to set a date, time and place for their public hearings. During the period between publication of the hearing notices and public hearings, each Service Council is provided a detailed presentation on service change proposals and given an opportunity to discuss the changes that will be the subject of public comment. After each hearing, each Service Council will meet to consider and approve, modify, or deny all proposed service changes. These actions will then be summarized and presented in an informational report to the Metro Board of Directors.

Under Metro's Service Council by-laws, all service changes must be reviewed and approved by their respective Service Council(s). Public hearings are usually held at the same location where the Service Councils hold their meetings but may be held at other locations at their discretion. When a major service change program requires three or more Councils to hold public hearings, an additional hearing will be held at a central location, normally at the Metro headquarters building, on an appropriate Saturday. In accordance with Metro's Administrative Code in Chapter 2-50 Public Hearings Subsection 2-50-020, Metro will hold a public hearing on all major service change or fare change proposals that are subject to a Title VI Equity Analysis. These proposals are subject to Metro Service Council and Metro Board approval.

6.6 Implementing Minor Changes on an Interim Basis

Minor service changes are generally route modifications that can be accommodated without impacting the vehicle or operator requirements of the service. Minor service changes do not require a public hearing but are shared with the relevant Service Councils as a courtesy and can be implemented at the discretion of staff.

APPENDICES

APPENDIX A: Metro Line Identification

The purpose of establishing transit service line identification standards is to create a simple way for customers to identify, locate, and reference Metro services, and thereby make the services easier for customers to use.

The line identification standards shall be adhered to when identifying Metro Bus and Metro Rail lines by name. The standards shall be implemented across all internal and external mediums including but not limited to, rail station signs, bus stop signs, bus station signs, vehicle head signs, vehicle destination signs, timetables, the Metro Transit Trip Planner, HASTUS and ATMS⁸. The descriptions and chart below help explain the standards, and how and when they should be implemented.

General Standards

- Transit service lines will be identified using a combination of line number, destinations (both terminals) and the corridor(s) the line travels along. Metro Rail and Metro BRT service which previously used the established operational names (e.g., Metro Red Line, Metro Purple Line, Metro Orange Line) are being transitioned to names based on a letter designation. To ensure consistent usage of transitional naming for Rail and BRT lines, updates to customer information should be referred to the Communications Department.
- Acceptable destination names include a city, community, major landmark, transit center or rail station. Street intersections are no longer to be used as a destination, unless the intersection is required to identify short-line service.
- The destination points will be listed in a West to East or North to South order, consistent with how the line would be read on a map. Destinations on head signs, destination signs, timetables, and physical signage must always be consistent.
- Lines that have Downtown LA as one of the line's end points will list it first, as Downtown LA.
- The name of the line will also list at least one major corridor on which it travels.
- Name abbreviations, street extensions and other topics will be dictated by the Metro Signage Guidelines.

Printed Materials and Electronic Customer Information

- The line will be presented using the full name, listing both the destinations and major corridor(s).
- Printed materials include, but are not limited to, timetables, service change announcements, brochures, system maps, and service reports.

⁸ HASTUS (Horaires et Assignments pour Systems de Transport Urban et Semi-Urban) refers to the software used to create schedules. ATMS (Advanced Transportation Management System)

- Electronic customer information includes the line information presented on metro.net and underlying electronic databases such as HASTUS and ATMS.
- The Metro Transit Trip Planner will present the line name similarly to what will be shown on the vehicle head sign and bus stop sign, so customers can easily locate the appropriate line at the stop.

Rail Station Signage

- The line will be presented using the line letter designation, and destination point that the vehicle is traveling to in each direction.

Bus Stop Signage

- The line will be presented using the line number, service brand, color and destination point that the vehicle is traveling to in each direction.
- The main corridor(s) will also be listed as well as special service qualifiers including, but not limited to, rush-hour service and weekday-only service.
- Short-line trip destinations will not be shown on bus stop signs.

Vehicle Head Signs

- Head signs will list the destination in which the vehicle is traveling towards in one frame.
- Head signs on Rail and BRT vehicles will list the line letter designation in one frame.
- For short-line trips, the line number and destination shown will be the destination of that trip and not of the entire line.
- When the line is not in service, the sign will read “Not in Service” and display the route number per Operations Notice #09-18.

Automatic Voice Announcements

- External On-Board Announcements:
 - The line will be identified in automatic external voice announcements using the line number and destination point that the vehicle is traveling to in each direction.
 - For short-line trips, the destination noted will be the destination of that trip and not of the entire line.
- Internal On-Board Announcements:
 - When the automatic voice announcement system identifies a stop, the end destination of that line will follow.
 - The stops and stations announced onboard should be consistent with names used on maps, timetables and other printed materials.







Assigning Line Identifiers

It is expected that the standards will be easily applied to the majority of lines; however, it is also understood that exceptions will have to be made for some lines due to unfamiliar end points or corridors, or where temporary solutions are necessary due to construction, temporary service changes, or pilot program deployment. In these limited cases, Service Planning staff and Communications must be in consensus regarding these changes before deciding to deviate from the standards. The Stop and Zones Department may also deploy temporary signage at bus and rail facilities as needed when emergency closures or other service changes impact scheduled service. For detailed guidance on using Metro signage standards, Metro Signage and Environmental Graphic Design Standards documents may be obtained from the Communications Department.

Metro's Rail Line Identification, Naming, and Color Conventions

Rail and BRT lines previously denoted by a color will transition to a letter/color combination beginning in November 2019 when the Metro Blue Line reopens after an extended upgrade. Metro's BRT lines will also transition to this naming convention. The letters assigned to each rail line generally conform to the order in which each line went into operation.

The current planned designations follow:

Prior Designation	Updated Designation	Updated Line Badge
Blue Line	A Line	
Red Line	B Line	
Green Line	C Line	
Purple Line	D Line	
Expo Line	E Line	
Orange Line	G Line	
Silver Line	J Line	
Gold Line	L Line	

The Gold Line has been assigned the letter L for clarity and consistency systemwide while service plans are being developed for the Regional Connector Project. When the Regional Connector is completed, the appropriate sections of the Gold Line will become the A Line or the E Line.

APPENDIX B: Los Angeles County Local Fixed and Demand Response Route Transit Operators

Operator	Municipal	Local Return
Agoura Hills		X
Alhambra		X
AVTA	X	X
Artesia		X
Avalon		X
Azusa		X
Baldwin Park		X
Beach Cities	X	X
Bell		X
Bell Gardens		X
Bellflower		X
Beverly Hills		X
Burbank		X
Calabasas		X
Carson		X
Cerritos		X
Commerce	X	X
Compton		X
Covina		X
Cudahy		X
Culver City	X	X
Downey		X
Duarte		X
El Monte		X
El Segundo		X
Foothill	X	X
Gardena	X	X
Glendale		X
Glendora		X
Hawthorne		X
Huntington Park		X
Inglewood		X

Operator	Municipal	Local Return
La Puente		X
Lawndale		X
Long Beach	X	X
Los Angeles	X	X
Los Angeles County		X
Lynwood		X
Manhattan Beach		X
Malibu		X
Maywood		X
Monrovia		X
Montebello	X	X
Monterey Park		X
Norwalk	X	X
Palos Verdes Estates		X
Paramount		X
Pasadena		X
Pico Rivera		X
Pomona		X
Redondo Beach		X
Rosemead		X
San Fernando		X
SCVTA	X	X
Santa Fe Springs		X
Santa Monica	X	X
Sierra Madre		X
South Gate		X
Torrance	X	X
West Covina		X
West Hollywood		X
Westlake Village		X
Whittier		X
Total	12	62

Many of the Local Return systems listed above do not provide fixed route service but instead provide Demand Response services: Hawthorne, Malibu, and Manhattan Beach are examples.



NEXTGEN Bus Plan



Metro

January 23, 2020
Regular Board Meeting

Building a World-Class Bus System

RIDERSHIP
RESOURCES

- 5 %
- 10 %

+ 5 %
0 %

+ 15-20 %
+ 10 %

+ 25-30 %
+ 20 %

Reduce operating resources

- Schedule to current demand
- Reduce duplication
- Discontinue unproductive segments
- No reallocation of resources

WHERE WE ARE >

Reconnect with our customers

- Create service tiers based on projected demand
- Connect the dots
- Coordinate with Muni
- Simplify routes and schedules
- Reallocate duplicative & unproductive service

Create a Transit First LA County

- Invest in speed and reliability infrastructure
- Create safe & comfortable waiting environments
- Establish facilities to optimize layovers
- Reinvest resources to improve lifeline services

Secure Future Funding

- Full buildout of consistent frequencies by service tiers
- Create all lines all day all week

Comparing the Alternatives

**Existing
Conditions
Today**

**Scenario A
Reconnect**

**Scenario B
Transit First**

**Scenario C
Future Funding**

Resources (Rev. Hrs)

7.0m

7.0m

7.0m

9.4m

Resources (Rev. Mi)

75.0m

75.0m

80.5m

105.0m

High-Frequency Lines (weekday)
Every 10 min or better

16

28

29

46

High-Frequency Lines (weekend)
Every 10 min or better

2

14

14

19

People w/walk access to high-frequency service
(weekday)

900,000

2.15m

2.17m

2.96m

People w/walk access to high-frequency service
(weekend)

630,000

1.14m

1.18m

1.49m

Ridership Increase

0

+5-10%

+15-20%

+25-30%

% riders who lose convenient walk access to transit

0

0.3%

0.3%

0.3%

Translating Lessons Learned Into Service Concepts

- **84% of LA County residents have used transit at least once in the past year**
Minimize discontinued segments
- **Fast/Frequent/Reliable service is key**
Create a competitive transit network
- **Metro's current system is not always competitive to get people where they want to go**
Build a network that reflects travel today & tomorrow
- **The greatest opportunity to grow ridership is between midday & evening when many trips are short distance**
Improve service for midday, evening & weekend
- **Need to integrate Metro's Equity Framework into the planning process**
Provide better service in equity-focused areas

The Metro Customer Experience



1 Speed & Reliability

Walk up & ride

Fast, reliable,
& predictable

Consistent & simple
routing



2 Stop Access & Waiting

Easy to find & access

Comfortable, convenient,
& well-informed

Safe and Secure



3 Boarding & Riding

Fast all-door boarding

Smooth, quiet ride

On-board information

NextGen Frequent Lines



Service Design Warrants

NextGen

Rapid

Frequent Headways	5-10 min	5-10 min
Stop Spacing	0.25-0.3 mi	0.5-0.75 mi
Transit Priorities/bus lanes	✓	✓
Bus Bulbs/Islands	✓	✗
Stop Amenities	✓	✓
Faster Boarding	✓	✗
Branded Buses and Stations	✗	✓
Headway Operations/Line Managers	✓	✓

Phasing Improvements

Capital investments create opportunities for system enhancements.

- Revenue Miles
- Capital Programs
- Current Operations

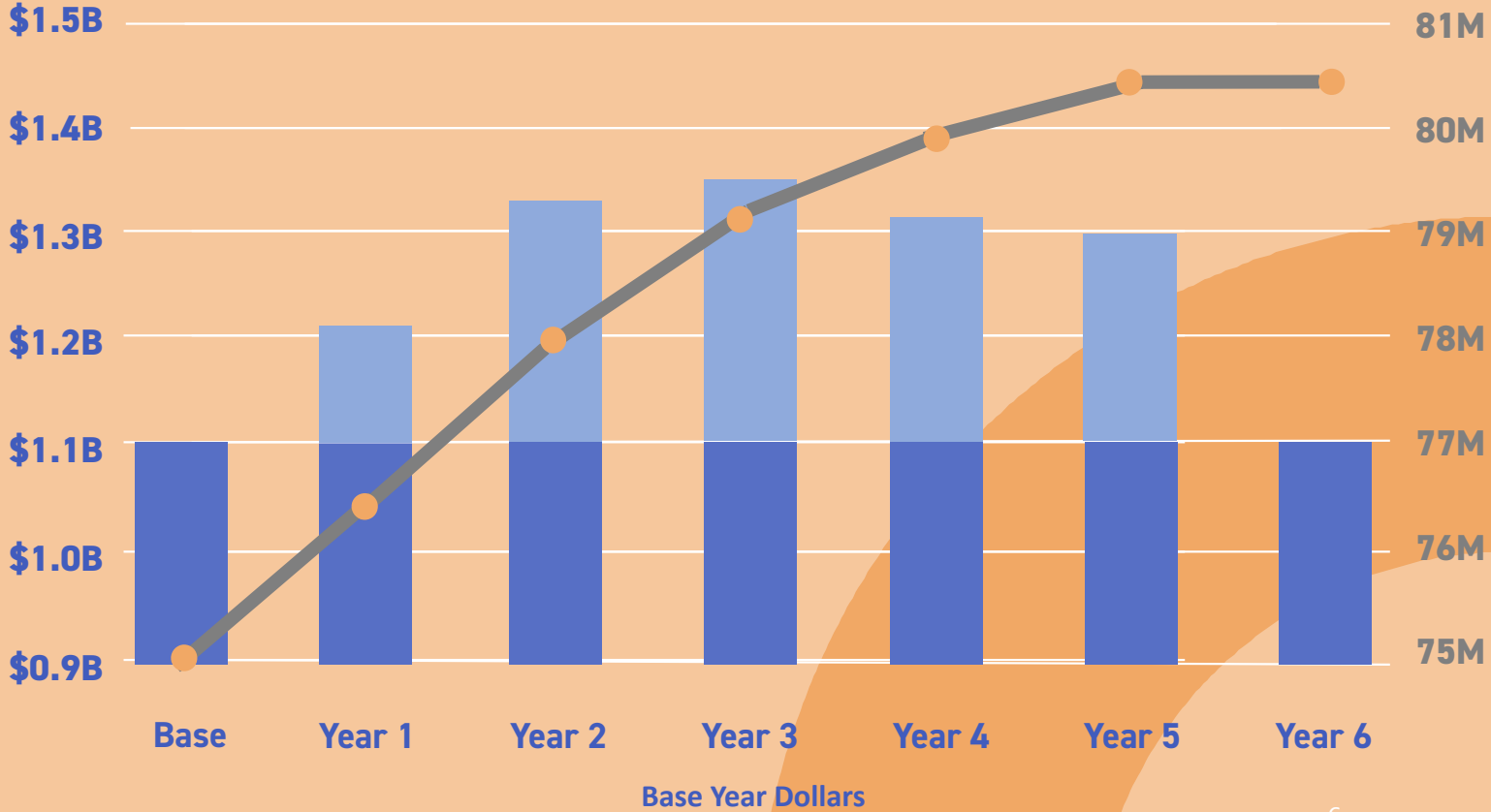

Transit First

The full network complements Muni lines, Metro Rail, & Metrolink services

83% of Metro's bus riders would have frequent service all-day (compared with 48% today)

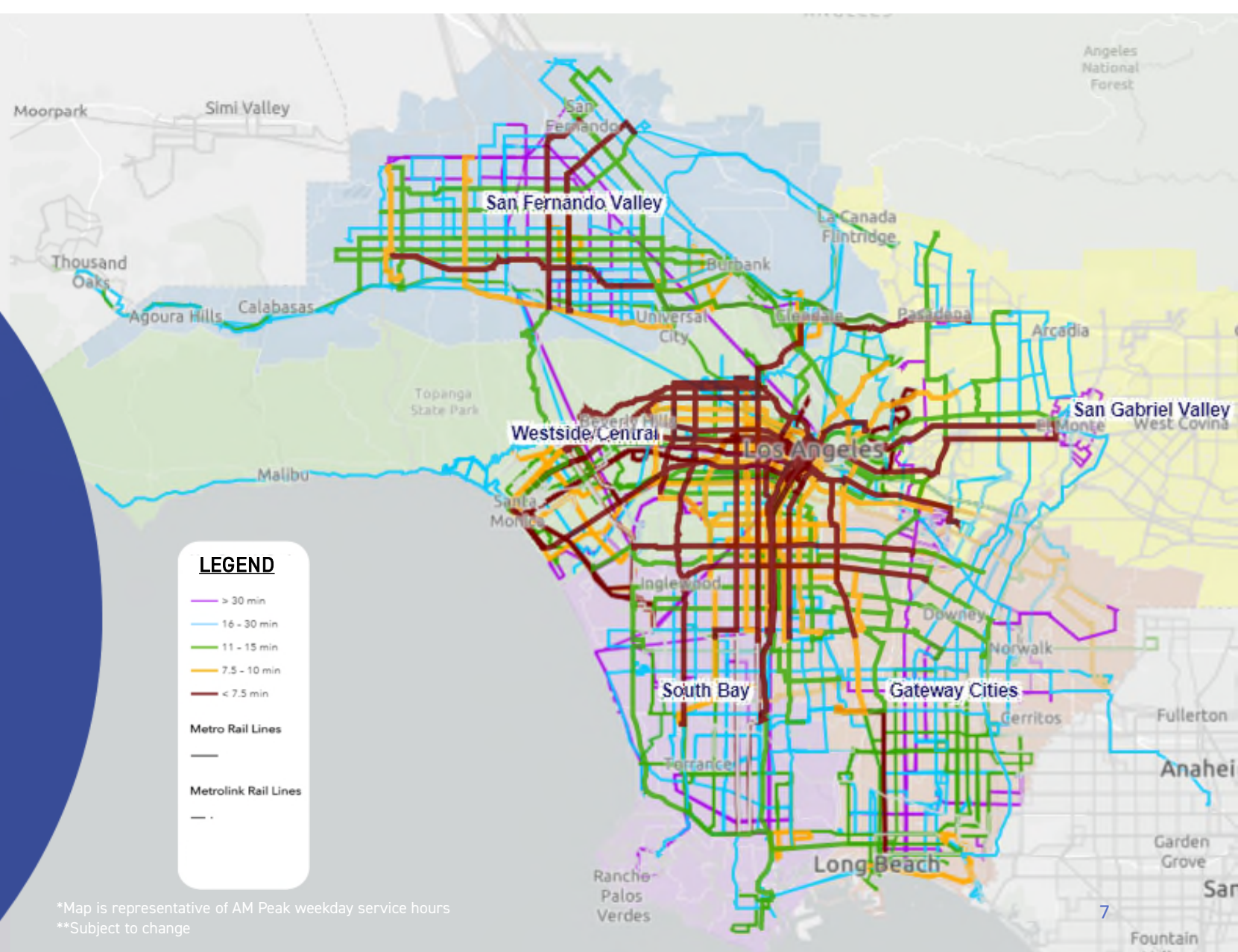

Next Steps



Historical Ridership Trends

		1985	1990	1997	2000	2005	2010	2015	2017	
1	Bus	LACMTA (Bus)	497,158,321	401,054,700	351,289,226	359,001,513	377,268,411	365,975,482	342,749,692	289,999,055
2		Muni Operators	54,900,600	65,573,000	87,838,916	105,579,793	135,992,801	137,095,260	127,749,026	99,059,684
3		Subtotal (Bus)	552,058,921	466,627,700	439,128,142	464,581,306	513,261,212	503,070,742	470,498,718	389,058,739
4		<i>Change</i>		-15%	-6%	6%	10%	-2%	-6%	-17%
5	Rail	LACMTA (Rail)			34,287,541	57,817,208	74,242,912	94,314,992	110,281,822	113,397,844
6		Metrolink			5,534,633	6,978,588	10,693,327	12,005,849	13,062,262	14,396,198
7		Subtotal (Rail)			39,822,174	64,795,796	84,936,239	106,320,841	123,344,084	127,794,042
8		<i>Ann Change</i>				63%	31%	25%	16%	4%
9	Access	Access Services					2,777,037	4,092,766	4,389,944	
10		<i>Ann Change</i>						47%	7%	
11	Total	Total (System)	552,058,921	466,627,700	478,950,316	529,377,102	598,197,451	612,168,620	597,935,568	521,242,725
12		<i>Ann Change</i>		-15%	3%	11%	13%	2%	-2%	-13%

Transit First

The full network complements Muni lines, Metro Rail, & Metrolink services

83% of Metro's bus riders would have frequent service all-day (compared with 48% today)

